















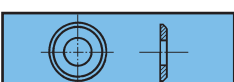



SKIVER











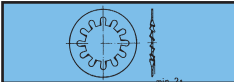
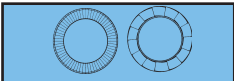



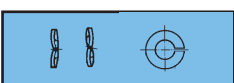

SIDE

	SKIVE OVERSIGT RUNDE SKIVE	
	SKIVE DIN 125 A UBEH, FZB, FZV	9:1, 9:2
	SKIVE SMS 70 HB 200 UBEH, FZB, FZV	9:3
	FACETSKIVE DIN 125 B UBEH, FZB, FZV	9:4
	FACETSKIVE SMS 70 HB 200 UBEH, FZB, FZV	9:4
	HRSB UBEH	9:5
	SBRB FZV	9:5
	SKIVE UBEH, FZB, FZV	9:6
	TBRB FZB	9:7
	TBRUB UBEH, FZB, FZV	9:7
	TBR SB FZB	9:8
	TBR SUB UBEH, FZB, FZV	9:8
	FJEDERSKIVE DIN 127 B UBEH, FZB, FZV	9:9
	FJEDERSKIVE DIN 7980 UBEH, FZB	9:10
	SKIVE FOR STÅLKONSTRUKTIONER DIN 6916 UBEH, FZB	9:10
	4-KANTSKIVE DIN 436 UBEH, FZB, FZV	9:11
	STOR 4-KANTSKIVE UBEH, FZB, FZV	9:11
	SIKRINGSSKIVE AZ DIN 6798 UBEH, FZB	9:12
	SIKRINGSSKIVE IZ DIN 6798 UBEH, FZB	9:12
	SIKRINGSSKIVE AZV DIN 6798 UBEH, FZB	9:12



SKIVER

SIDE

	SIKRINGSSKIVE AZ DIN 6797 UBEH, FZB	9:13
	SIKRINGSSKIVE IZ DIN 6797 UBEH, FZB	9:13
	NORDLOCKSKIVER GULKROM	9:14
	SCHNORRSKIVE UBEH, FZB	9:15
	NITTESKIVE UBEH, FZB	9:16
	SRKB KAROSSERISKIVE UBEH, FZB	9:17
	FJEDERSKIVE DIN 128 A OG B UBEH, FZB	9:18
	FJEDERSKIVE DIN 137 A UBEH, FZB	9:19
	FJEDERSKIVE DIN 137 B UBEH, FZB	9:19
	TALLERKENFJEDERSKIVE DIN 2093	9:20, 9:21, 9:22
	SKRÅSKIVE DIN 434 UBEH, FZB, FZV	9:23
	SKIVE DIN 433 UBEH, FZB	9:23
	SKIVE DIN 126 UBEH, FZB, FZV	9:24
	PASSKIVE DIN 988-S UBEH	9:25
	PASSKIVE DIN 988 UBEH	9:26, 9:27, 9:28
	SKIVE DIN 1440 UBEH/FZB	9:29
	SKIVE DIN 1441 UBEH/FZB	9:30
	SKIVE DIN 7989 A UBEH, FZB, FZV	9:31

SKIVER

SIDE

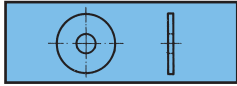

SKÆRMSKIVE DIN 9021 UBEH, FZB

9:31

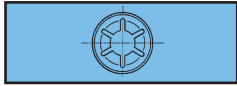

A-LOCK LÅSESKIVE UDEN KAPSEL, MED KAPSEL

9:32



STARLOCK LÅSESKIVE UDEN KAPSEL, MED KAPSEL

9:33

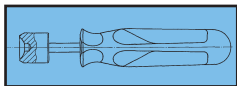

MONTERINGSVÆRKTØJ FOR STARLOCK

9:34

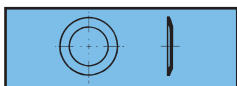

FJEDERSKIVE DIN 6796 FOSFATERET/MEKANISK FZB

9:35

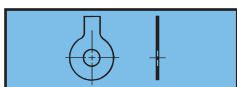

SIKRINGSSKIVE DIN 93 UBEH, FZB

9:36

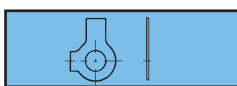

SIKRINGSSKIVE DIN 463 FZB

9:37

OVERSIGT RUNDE PLANE SKIVER STÅL

Denne oversigt angiver kun skivernes nominelle mål. Vil man have oplysninger om tolerancer og øvrige tekniske specificationer fremgår det ved respektive normer og standarder. For information om øvrige dimensioner, kontakt vore salgsafdeling.

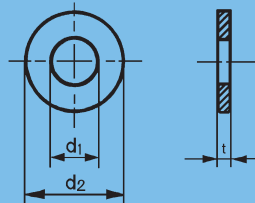

d1	d2	t	DIN	ISO	SS SMS	BN VSM	BS	TYPE	SIDE	d1	d2	t	DIN	ISO	SS SMS	BN VSM	BS	TYPE	SIDE
3,2	6	0,5	433	7092	70			BRB	3, 23	6,4	16	0,8				735			
3,2	7	0,5	125	7089	3576		4320	BRB	1	6,4	16	1,6				737			
3,2	9	0,8	9021	7093					30	6,4	17	3	7349						
3,2	9	1	7349							6,4	18	1,6	9021	7093					30
3,2	10	0,5				735				6,4	20	1,5				732			
3,2	13	0,5				735				6,4	22	4			1466			TBRBSB	8
										6,4	25	1,8				732			
3,7	7	0,5	433	7092			4320		3, 23										
3,7	7	0,8			70			BRB	3	6,6	12	1,6	126	7091					24
3,7	8	0,5	125	7089	3576			BRB	1	6,6	22	2		7094					
3,7	11	0,8	9021	7093					30										
4	8	0,8		8738						6,7	14	1,5			70			BRB	3
4	9	0,5			71			SRB	6	6,7	14	3			1466			TBRB	9
4	10	1			71			SRB	6	6,7	22	4			1466			TBRBSB	8
4,3	8	0,5	433	7092					23	7	11	2				739			
4,3	8	0,8			70			BRB	3	7	12	1,5			71			SRB	6
4,3	9	0,8	125	7089	3576		4320	BRB	1	7	14	1,5			71			SRB	6
4,3	10	0,8					4320			7	16	1,5			71			SRB	6
4,3	12	1	9021	7093					30	7	19	1,5						SRKB	17
4,3	12	1,6	7349							7	22	1,5						SRKB	17
4,3	14	0,8				735				7	25	1,5						SRKB	17
										7	28	2						SRKB	17
										7	35	2						SRKB	17
4,8	10	0,8			70			BRB	3	7	35	3						SRKB	17
5	10	1		8738						7,4	14	1,5	125		70			BRB	3
5	13	1						NB	16	7,4	14	1,6						BRB	1
5	16	1						NB	16	7,4	17	0,8				735			
5	19	1						NB	16	7,4	17	1,6				737			
5	22	1						NB	16	7,4	20	1,5				732			
5	25	1						NB	16	7,4	25	1,8				732			
										7,4	35	2,5				732			
5,3	9	1	433	7092					23										
5,3	10	0,8					4320			7,6	14	1,6	126						24
5,3	10	1	125	7089	3576		4320	BRB	1, 3	7,6	14	1,8	9021						30
					/70														
5,3	15	0,8				735				8	12	2				739			
5,3	15	1,2	9021	7093					30	8	14	1,5			71			SRB	6
5,3	15	2	7349							8	15	2			8738				
5,3	20	1,5				732				8	16	1,5						NB	16
										8	19	1,5						NB	16
5,5	10	1	126	7091				SRB	24	8	22	1,5						NB	16
5,5	12	1			71				6	8	25	1,5						NB	16
5,5	12,5	1					4320												
5,5	18	2		7094						8,4	15	1,6	433	7092					23
5,5	22	1,5						SRKB	17	8,4	16	1,5			70			BRB	3
5,5	25	1,5						SRKB	17	8,4	16	1,6	125	7089	3576			BRB	1
										8,4	16	3			1466			TBRB	9
6	12	1,6		8738						8,4	17	1					4320		
6	16	1						NB	16	8,4	17	1,6					4320		
6	19	1						NB	16	8,4	20	1,2				735			
6	22	1,5						NB	16	8,4	20	2				737			
6	25	1,5						NB	16	8,4	21	1					4320		
										8,4	21	1,6					4320		
6,4	11	1,6	433	7092					23	8,4	21	4	7349						
6,4	12	1,5			70			BRB	3	8,4	24	2	9021	7093					30
6,4	12	1,6	125	7089	3576			BRB	1	8,4	25	1,8						732	
6,4	12	3			1466			TBRB	9	8,4	26	5			1466				TBRBSB
6,4	12,5	0,8					4320			8,4	30	2						732	
6,4	12,5	1,6					4320			8,4	35	2,5						732	
6,4	14	0,8					4320												
6,4	14	1,6					4320												

d1	d2	t	DIN	ISO	SS SMS	BN VSM	BS	TYPE	SIDE	d1	d2	t	DIN	ISO	SS SMS	BN VSM	BS	TYPE	SIDE
9	13	2				739				13,5	24	2			70			BRB	3
9	16	1,5			71			SRB	6	13,5	24	2,5	126	7091					24
9	16	1,6	126	7091					24	13,5	24	4			1466			TBRB	9
9	18	1,5			71			SRB	6	13,5	36	6			1466			TBRB	8
9	28	2						SRKB	17	13,5	44	4			7094				
9	28	3			7094														
9	35	2						SRKB	17	14	18	2				739			
9,4	30	2				732				14	22	3			8738				
9,4	35	2,5				732				14	24	2			71			SRB	6
9,4	40	2,5				732				14	24	8	7989		71			SRB	31
										14	28	2			71			SRB	6
10	14	2				739				15	20	2				739			
10	18	2			70			BRB	3	15	24	2,5	433	7092					23
10	18	2,5		8738						15	26	2			70			BRB	3
10	18	4			1466			TBRB	9	15	28	1,6				4320			
10	19	1,5						NB	16	15	28	2,5	125	7089	3576		4320	BRB	1
10	22	1,5						NB	16	15	30	4				13904			
10	25	1,5						NB	16	15	35	1,6				735			
10	28	6			1466			TBRB	8	15	35	3				737			
10,5	18	1,6	433	7092					23	15	36	6	7349						
10,5	20	2	125	7089	3576			BRB	1	15	44	3	9021	7093					30
10,5	21	1,25				4320				15	52	5				2045			
10,5	21	2				4320				15,5	26	2			71			SRB	6
10,5	22	2			70			BRB	3	15,5	28	2,5	126	7091					24
10,5	22	4			1466			TBRB	9	15,5	50	4			7094				
10,5	24	1,25				4320										739			
10,5	24	2				4320				16	22	2							
10,5	25	1,2				735				16	24	3			8738				
10,5	25	2				737													
10,5	25	4	7349							17	28	2,5	433	7092					23
10,5	28	6			1466			TBRB	8	17	30	2				4320			
10,5	30	2				732				125	7089	3576	125	7089	3576		4320	BRB	1,3
10,5	30	2,5	9021	7093					30	17	30	3			/70				
10,5	35	2,5				732				17	30	4	6916						10
10,5	40	2,5				732				17	30	6			1466			TBRB	9
										17	34	2				4320			
										17	34	3				4320			
11	15	2				739				17	34	4			13904				
11	18	2			71			SRB	6	17	34	4			735				
11	20	2	126	7091					24	17	40	1,6			737				
11	21	8	7989						30	17	40	3							
11	22	2			71			SRB	6	17	40	6	7349						
11	34	3			7094					17	42	8			1466			TBRB	8
										17	50	3	9021	7093					30
12	16	2				739				17	58	5				2045			
12	20	3		8738						17	68	6				2045			
12	22	2			70			BRB	3										
12,5	22	2			71			SRB	6	17,5	30	3	126	7091	71			SRB	6,24
12,5	26	2			71			SRB	6	17,5	34	3			71			SRB	6
										17,5	56	5			7094				
13	17	2				739				18	24	2				739			
13	20	2	433	7092					23	18	28	4			8738				
13	24	1,6				4320				18	30	8	7989						31
13	24	2			70			BRB	3										
13	24	2,5	125		3576	4320		BRB	1	19	30	2,5	433						
13	24	3	6916					TBRB	10	19	34	2				4320			
13	24	4			1466				9	19	34	3	125		3576		4320	BRB	1,3
13	28	1,6				4320									/70				
13	28	2,5				4320				19	37	4				13904			
13	28	4				13904				19	44	8	7349						
13	30	1,6				735				19	50	2				735			
13	30	3				737				19	50	4				737			
13	30	6	7349							19	68	6				2045			
13	36	6			1466			TBRB	8										
13	37	3	9021	7093					30	20	30	4			8738				
13	45	2,5				732				20	34	3	126		71			SRB	6,24
13	45	4				2045				20	36	3			70			BRB	3
										20	36	6			1466			TBRB	9
										20	52	8			1466			TBRB	8
										20	56	4	9021					TBRB	30

BUFAB

SKIVE

DIN 125 A (~SS 3576, ~ISO 7089)

min.HV 140 UBEHANDLET, FZB, FZV

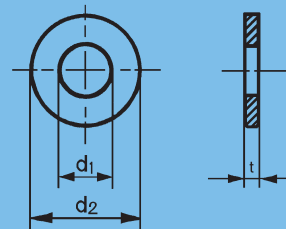

FOR SKRUE M- ENG/AM- GEVIND GEVIND		d1	d2	t	PRIS PR. 100 STK.							
					SMÅPAK		IND.PAK		NORMALPAK			
					PAKKEP.	PRIS	PAKKEP.	PRIS	UBEH PAKKEP. PRIS	FZB PRIS	FZV PRIS	
M2		2,2	5	0,3	100	19:-			500	15:-	16:-	
M2,3		2,5	6	0,5	100	19:-			500	15:-	16:-	
M2,5		2,7	6	0,5	100	12:-			500	15:-	9:-	
M2,6		2,8	7	0,5					500	55:-	56:-	
M3		3,2	7	0,5	100	7:-	5000	4:-	1000	7:-	5:-	
M3,5		3,7	8	0,5			5000	8:-	500	10:-	9:-	
M4		4,3	9	0,8	100	8:-	5000	5:-	1000	8:-	6:-	
M4,5		4,8	10	0,8	100	21:-	5000	18:-	500	39:-	19:-	
M5		5,3	10	1	100	10:-	5000	6:-	500	9:-	7:-	
M6		6,4	12	1,6	250	14:-	5000	11:-	500	13:-	12:-	37:-
	1/4	6,7	14	1,5	100	18:-	5000	15:-	500	20:-	16:-	55:-
M7		7,4	14	1,6					500	39:-	34:-	
M8	5/16	8,4	16	1,6	200	21:-	5000	18:-	500	21:-	19:-	42:-
	3/8	10	18	2	100	32:-	3000	28:-	200	34:-	29:-	75:-
M10		10,5	20	2	100	39:-	3000	34:-	200	38:-	35:-	65:-
	7/16	12	22	2	100	55:-	2000	47:-	200	52:-	48:-	110:-
M12		13	24	2,5	100	57:-	1000	48:-	200	56:-	49:-	83:-
	1/2	13,5	24	2,5	100	94:-	1000	84:-	200	98:-	86:-	96:-
M14		15	28	2,5	100	95:-	1000	86:-	200	119:-	89:-	129:-
M16	5/8	17	30	3	50	106:-	500	94:-	100	129:-	97:-	149:-
M18		19	34	3	50	165:-	500	151:-	100	169:-	155:-	210:-
	3/4	20	36	3					100	340:-	332:-	390:-
M20		21	37	3	25	187:-	500	172:-	50	170:-	178:-	275:-
M22	7/8	23	39	3					50	258:-	269:-	396:-
M24		25	44	4					50	375:-	390:-	598:-
	1"	26	45	4					50	440:-	450:-	790:-
	1"	27	50	4					50			1800:-

BEST.EX: DIN 125 2,2 x 5 x 0,3 FZB
DATA.EX: 1250221

HVIS IKKE ANDET ØNSKES LEVERES NORMALPAK

SKIVE

DIN 125 A (~SS 3576, ~ISO 7089)

min.HV 140 UBEHANDLET, FZB, FZV

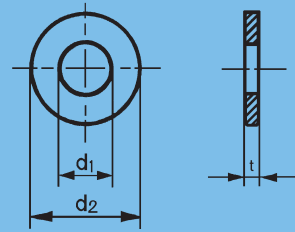

FOR SKRUE M- GEVIND		ENG/AM- GEVIND	d1	d2	t	PAKKEP.	PRIS PR. 100 STK.		
							UBEH	FZB	FZV
M27			28	50	4	50	840:-	850:-	2900:-
M30	1 1/8		31	56	4	50	920:-	940:-	2950:-
M33	1 1/4		34	60	5	50	1850:-	1900:-	3100:-
M36	1 3/8		37	66	5	50	2055:-	2100:-	3100:-
M39	1 1/2		40	72	6	50	3900:-	4020:-	
M42			43	78	7	25	6300:-	6480:-	
M45	1 3/4		46	85	7	25	6900:-	7200:-	
M48			50	92	8	25	9724:-	10320:-	
M52	2"		54	98	8	LØSE	13700:-	15000:-	
M56			58	105	9	LØSE	19298:-	20640:-	29000:-
	2 1/4		60	110	9	LØSE	23100:-	24000:-	
M60			62	110	9	LØSE	23100:-	24000:-	46000:-
M64	2 1/2		66	115	9	LØSE	23900:-	24240:-	
M68			70	120	10	LØSE	39000:-	42000:-	
M72	2 3/4		74	125	10	LØSE	41900:-	42600:-	
M76	3"		78	135	10	LØSE	49800:-	51600:-	
M80			82	140	12	LØSE	61000:-	63600:-	
M90	3 1/2		93	160	12	LØSE	79600:-	88800:-	

BEST.EX: DIN 125 27 x 50 x 4 FZB
DATA.EX: 1252701

SKIVE HÆRDET
SMS 70 (~SS 3576)
HB 200 UBEHANDLET, FZB, FZV

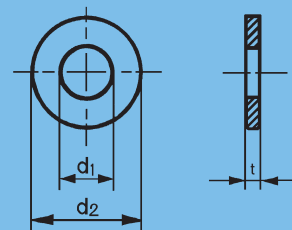

FOR SKRUE M- GEVIND		d1	d2	t	PAKKEP.	PRIS PR. 100 STK.		
						UBEH	FZB	FZV
M3		3,2	6	0,5	1000	10:–	10:–	
M3,5		3,7	7	0,8	500	48:–	19:–	
M4		4,3	8	0,8	1000	11:–	11:–	
M4,5		4,8	10	0,8	500	50:–	55:–	
M5		5,3	10	1	500	13:–	13:–	
M6		6,4	12	1,5	500	20:–	25:–	40:–
	1/4	6,7	14	1,5	500	28:–	33:–	55:–
M7		7,4	14	1,5	500	45:–	55:–	75:–
M8	5/16	8,4	16	1,5	500	28:–	33:–	65:–
	3/8	10	18	2	200	45:–	55:–	75:–
M10		10,5	22	2	200	60:–	75:–	110:–
	7/16	12	22	2	200	60:–	75:–	110:–
M12		13	24	2	200	70:–	85:–	130:–
	1/2	13,5	24	2	200	98:–	90:–	130:–
M4		15	26	2	200	119:–	120:–	160:–
M16	5/8	17	30	3	100	170:–	210:–	270:–
M18		19	34	3	100	250:–	310:–	400:–
	3/4	20	36	3	100	340:–	332:–	390:–
M20		21	36	3	50	230:–	280:–	380:–
M22	7/8	23	40	3	50	320:–	390:–	520:–
M24		25	45	4	50	560:–	680:–	900:–
	1"	26	45	4	50	600:–	700:–	900:–

BEST.EX: SKIVE HB 200 3,2 FZB
DATA.EX: BRB0321

FACETSKIVE

DIN 125 B (~SS 3576, ~ISO 7090)

min.140 HV UBEHANDLET, FZB, FZV

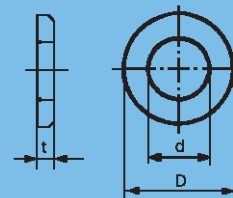

FOR SKRUE M- GEVIND		d1	d2	t	PAKKEP.	PRIS PR. 100 STK.		
ENG/AM- GEVIND						UBEH	FZB	FZV
M20	7/8	21	37	3	200	304:-	432:-	512:-
M22		23	39	3	200	376:-	528:-	640:-
M24		25	44	4	200	656:-	920:-	1120:-
M27		28	50	4	100	920:-	1280:-	1480:-
M30		31	56	4	100	1200:-	1400:-	1360:-
M32		33	60	5	50		1600:-	
M33		34	60	5	100	2360:-	2600:-	3080:-
M36		37	66	5	100	2500:-	2700:-	3400:-
M39	1 1/2	40	72	6	50		5400:-	6400:-
M42	1 3/4	43	78	7	25	4960:-	5520:-	6440:-
M45		46	85	7	25	7800:-	8500:-	11200:-
M48		50	92	8	25	7960:-	8760:-	12300:-
M52		54	98	8	25			17000:-
BEST.EX: DIN 127 21 x 37 x 3 FZB DATA.EX: 125B211								

FACETSKIVE HÆRDET

SMS 70 (~DIN 125 B, ~SS 3576)

HB 200 UBEHANDLET, FZB, FZV

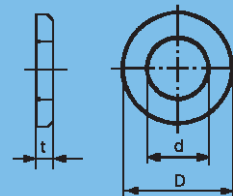

FOR SKRUE M- GEVIND		d	D	t	PAKKEP.	PRIS PR. 100 STK.		
ENG/AM- GEVIND						UBEH	FZB	FZV
M20	3/4	20	36	3	200	700:-	960:-	1100:-
M22		21	36	3	200	380:-	540:-	640:-
M24	7/8	23	40	3	200	470:-	660:-	800:-
M24		25	45	4	200	820:-	1150:-	1400:-
	1"	26	45	4	200	820:-	1500:-	1400:-
M27			28	52	4	100	1150:-	1600:-
	1 1/8	30	52	4	100	1250:-	1700:-	2050:-
M30			31	58	4	50	1500:-	1750:-
M32	1 1/4	33	58	4	100	1750:-	2000:-	2400:-
M33		34	62	4	100	2950:-	3250:-	3850:-
	1 3/8	36	62	5	100	3900:-	4250:-	4850:-
M36			37	68	5	100	2800:-	3250:-
	1 1/2	40	68	5	50	2900:-	3300:-	3850:-
M39			40	75	5	50	9250:-	9950:-
M42		43	80	6	25	6200:-	6900:-	8050:-
	1 3/4	46	80	6	25	7050:-	7750:-	8750:-
M45			46	85	6	25	17100:-	18150:-
M48	2"	50	92	6	25	9950:-	10950:-	12500:-
			53	92	6	25	9850:-	10800:-
BEST.EX: FACETSKIVE HB 200 20 x 36 x 3 FZB DATA.EX: BRFB2001								

HRSB HÆRDED SKIVE FOR FRIKTIONSSAMLING

STÅL SIS 1550

SEJHÆRDET 35-45 HRC UBEHANDLET

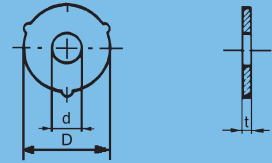

FOR SKRUE M- GEVIND		ENG/AM- GEVIND	d	D	t	PAKKEP.	PRIS PR. 100 STK.
M16		5/8	17,5	35	3,5	100	700:–
		3/4	21	40	4,0	100	940:–
M22		7/8	24	45	4,0	100	5500:–
		1"	27	50	4,0	100	4150:–

BEST.EX: HRSB STÅL 17,5 x 35 x 3,5 UBEHANDLET
DATA.EX: HRSB175

SBRB

RUND SKIVE FOR SB 8.8 BOLTE

FZV

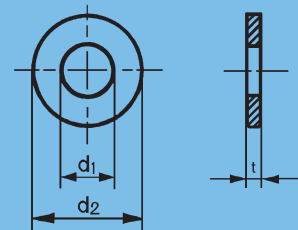

FOR SKRUE M- GEVIND		ENG/AM- GEVIND	d1	d2	t	PAKKEP.	PRIS PR. 100 STK.
M12		1/2	13	24	7	200	720:–
M16		5/8	17	30	7	200	920:–
M20		3/4	21	37	7	200	1250:–
M22		7/8	23	39	7	200	2550:–
M24		1"	25	44	7	200	1600:–

BEST.EX: SBRB 13 x 24 x 7 FZV
DATA.EX: SBRB1302

SKIVE

SMS 71

UBEHANDLET, FZB, FZV

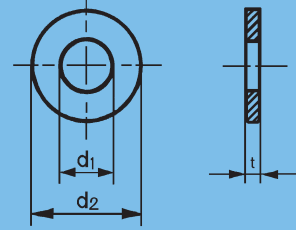

FOR SKRUE		d	D	t	PAKKEP.	PRIS PR. 100 STK.		
M-GEVIND	ENG/AM-GEVIND					UBEH	FZB	FZV
M6	1/8	4	9	0,5	500	25:-	28:-	
	5/32	4	10	1	500	15:-	14:-	
	3/16	5,5	12	1	200	20:-	19:-	
		7	12	1,5	200	65:-	49:-	
	1/4	7	14	1,5	200	60:-	49:-	
M6	1/4	7	16	1,5	200	28:-	26:-	70:-
M7		8	14	1,5	200	60:-	55:-	
M8	5/16	9	16	1,5	200	60:-	55:-	100:-
M8	5/16	9	18	1,5	200	35:-	33:-	85:-
	3/8	11	18	2	200	120:-	59:-	150:-
M10	3/8	11	22	2	200	60:-	53:-	110:-
	7/16	12,5	22	2	200	85:-	69:-	140:-
	7/16	12,5	26	2	200	80:-	69:-	160:-
M12	1/2	14	24	2	200	130:-	150:-	200:-
M12	1/2	14	28	2	200	95:-	86:-	180:-
M14		15,5	26	2	200	210:-	230:-	280:-
M16	5/8	17,5	30	3	100	280:-	198:-	410:-
M16	5/8	17,5	34	3	100	190:-	180:-	350:-
M18		20	34	3	100	520:-	580:-	680:-
M20	3/4	21	36	3	100	230:-	220:-	390:-
M20	3/4	21	40	3	100	260:-	240:-	460:-
M22	7/8	24	40	3	100	320:-	310:-	520:-
M22	7/8	24	45	3	100	400:-	500:-	680:-
M24		26	45	4	100	580:-	700:-	900:-
	1"	27	45	4	100	440:-	560:-	740:-
M27	1"	27	52	4	100	660:-	820:-	1100:-
		29	52	4	100	680:-	860:-	1150:-
	1 1/8	31	52	4	100	660:-	800:-	1100:-
M30	1 1/8	31	58	4	100	880:-	1200:-	1550:-
M33	1 1/4	34	58	4	100	900:-	1100:-	1450:-
M33	1 1/4	34	62	4	100	1650:-	1950:-	2350:-
M36	1 3/8	37	62	5	100	1450:-	1750:-	2100:-
M36	1 3/8	37	68	5	100	2900:-	3450:-	3950:-
M39	1 1/2	40	68	5	50	1750:-	1850:-	2500:-
M39	1 1/2	40	75	5	50	3400:-	3950:-	4550:-
M42	1 5/8	44	80	6	50	5100:-	5900:-	6650:-
M45	1 3/4	47	80	6	50	5100:-	5900:-	6650:-
M45	1 3/4	47	85	6	50	7850:-	8750:-	9900:-
M48		50	92	6	50	8200:-	9400:-	10600:-
	2"	54	92	6	50	5650:-	6600:-	7550:-
	2"	54	98	6	50	8600:-	9850:-	11000:-

BEST.EX: SKIVE 4 x 9 x 0,5 FZB
 DATA.EX: SRB040091

TBR SB TYK RUND FACETSKIVE

SMS 1466

FZB

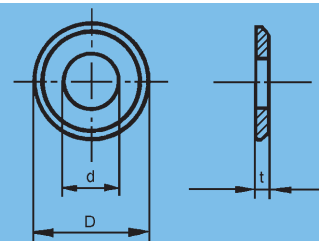

FOR SKRUE		d	D	t	PAKKEP.	PRIS PR. 100 STK.		
M-GEVIND	ENG/AM-GEVIND							
M6		6,4	12	3	200		220:-	
	1/4	6,7	14	3	200		240:-	
M8	5/16	8,4	16	3	200		250:-	
	3/8	10	18	4	200		300:-	
M10		10,5	22	4	200		400:-	
M12		13	24	4	200		400:-	
	1/2	13,5	24	4	200		450:-	
M16	5/8	17	30	6	100		940:-	
	3/4	20	36	6	100		2200:-	
M20		21	36	6	100		1200:-	
	7/8	23	40	6	100		1650:-	
M24		25	45	8	50		3500:-	
	1"	26	45	8	50		3700:-	
M30		31	58	8	50		5550:-	
	1 1/4	33	58	8	50		9100:-	
M36		37	68	10	50		9800:-	
	1 1/2	40	68	10	50		9650:-	

BEST.EX: TBRB 6,4 x 12 x 3 FZB
DATA.EX: TBRB0641

TBR SUB TYK RUND SKIVE UDEN FAS

(~SMS 1466)

UBEHANDLET, FZB ,FZV

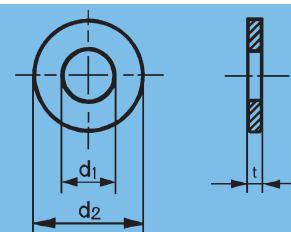

FOR SKRUE		d1	d2	t	PAKKEP.	PRIS PR. 100 STK		
M-GEVIND	ENG/AM-GEVIND					UBEH	FZB	FZV
M6		6,4	12	3	200		154:-	
	1/4	6,7	14	3	200		168:-	
M8	5/16	8,4	16	3	200	165:-	175:-	
	3/8	10	18	4	200	190:-	210:-	
M10		10,5	22	4	200	260:-	280:-	
M12		13	24	4	200		285:-	
M16	5/8	17	30	6	100	630:-	658:-	790:-
M20		21	36	6	100		840:-	
	7/8	23	40	6	100		1155:-	
M24		25	45	8	50		2450:-	
	1"	26	45	8	50		2590:-	
M30		31	58	8	50		3885:-	
	1 1/4	33	58	8	50		6370:-	

BEST.EX: TBRUB 6,4 x 12 x 3 FZB
DATA.EX: TBRUB0641

TBR SB

TYK RUND FACETSKIVE MED STOR DIAMETER FZB

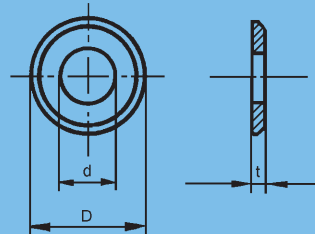

FOR SKRUE		d	D	t	PAKKEP.	PRIS PR. 100 STK.	
M-GEVIND	ENG/AM-GEVIND					FZB	
M6		6,4	22	4	200	400:-	
	1/4	6,7	22	4	200	400:-	
M8	5/16	8,4	26	5	200	700:-	
	3/8	10	28	6	200	1250:-	
M10		10,5	28	6	200	720:-	
M12		13	36	6	100	1100:-	
	1/2	13,5	36	6	100	1250:-	
M16	5/8	17	42	8	100	2850:-	
	3/4	20	52	8	50	5900:-	
M20		21	52	8	50	4200:-	
	7/8	23	58	10	50	6850:-	
M24		25	58	10	50	6050:-	
	1"	26	65	10	25	7850:-	
	1 1/4	31	75	12	25	16450:-	

BEST.EX: TBR SB 6,4 x 22 x 4 FZB
DATA.EX: TBR SB0641

TBR SUB

TYK RUND SKIVE MED STOR DIAMETER UBEHANDLET, FZB, FZV

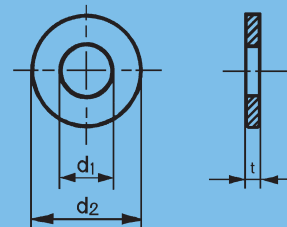

FOR SKRUE		d1	d2	t	PAKKEP.	PRIS PR. 100 STK.		
M-GEVIND	ENG/AM-GEVIND					UBEH	FZB	FZV
M6		6,4	22	4	200		280:-	350:-
	1/4	6,7	22	4	200		280:-	
M8	5/16	8,4	26	5	200	480:-	490:-	590:-
	3/8	10	28	6	200		875:-	
M10		10,5	28	6	200		504:-	650:-
M12		13	36	6	100	760:-	770:-	890:-
	1/2	13,5	36	6	100		875:-	
M16	5/8	17	42	8	100		1995:-	2200:-
	3/4	20	52	8	50		4130:-	4900:-
M20		21	52	8	50		2940:-	3700:-
	7/8	23	58	10	50		4795:-	
M24		25	58	10	50		4235:-	5200:-
	1"	26	65	10	25		5495:-	
	1 1/4	33	75	12	25		9900:-	

BEST.EX: TBR SUB 6,4 x 22 x 4 FZB
DATA.EX: TBR SUB0641

FJEDERSKIVE

DIN 127 B

FJEDERSTÅL UBEHANDLET, FZB, FZV

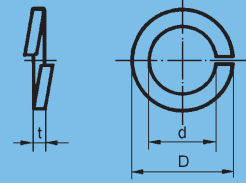

FOR SKRUE		d	D	t	PAKKEP.	PRIS PR. 100 STK.		
M-GEVIND	ENG/AM-GEVIND					UBEH	FZB	FZV
M2		2,1	4,4	0,5	1000	16:-	11:-	
M2,3		2,4	4,9	0,6	1000		16:-	
M2,5		2,6	5,1	0,6	1000	16:-	16:-	
M2,6		2,7	5,2	0,6	1000	22:-	17:-	
M3	1/8	3,1	6,2	0,8	1000	16:-	9:-	
M3,5		3,6	6,7	0,8	1000	16:-	14:-	
M4	5/32	4,1	7,6	0,9	1000	16:-	10:-	
M4,5		4,8	8,4	1,2	1000		29:-	
M5	3/16	5,1	9,2	1,2	500	19:-	13:-	
M6		6,1	11,8	1,6	500	22:-	17:-	
	1/4	6,5	12,2	1,6	1000	68:-	32:-	
M7		7,1	12,8	1,6	1000	49:-	34:-	
M8	5/16	8,1	14,8	2,0	500	38:-	22:-	110:-
	3/8	9,7	16,7	2,2	500	56:-	39:-	
M10		10,2	18,1	2,2	500	45:-	33:-	158:-
	7/16	11,3	18,3	2,2	500	86:-	82:-	
M12		12,2	21,1	2,5	200	63:-	54:-	232:-
	1/2	13,0	21,0	2,5	200	110:-	96:-	365:-
M14		14,2	24,1	3,0	200	97:-	67:-	390:-
M16	5/8	16,2	27,4	3,5	200	139:-	99:-	504:-
M18		18,2	29,4	3,5	200	260:-	182:-	558:-
	3/4	19,3	31,3	4,0	100	390:-	328:-	
M20		20,2	33,6	4,0	100	270:-	162:-	789:-
M22	7/8	22,5	35,9	4,0	100	450:-	321:-	1173:-
M24		24,5	40,0	5,0	100	520:-	340:-	1338:-
	1"	25,8	39,8	5,0	100	980:-	790:-	2193:-
M27		27,5	43,0	5,0	100	990:-	661:-	1566:-
M30	1 1/8	30,5	48,2	6,0	25	1323:-	704:-	2658:-
M32	1 1/4	32,3	48,3	6,0	25	1900:-	990:-	
M33		33,5	55,2	6,0	25	2600:-	2300:-	
M36		36,5	58,2	6,0	25	2900:-	2495:-	
	1 1/2	38,6	58,6	6,0	25	3500:-	2700:-	
M42	1 5/8	42,5	68,2	7,0	25	4836:-	5767:-	
M45	1 3/4	45,5	71,2	7,0	25	8337:-	8595:-	
M48	1 3/4	49,0	75,0	7,0	25	8600:-	8976:-	

BEST.EX: DIN 127 2,1 UBEHANDLET
DATA.EX: 127021

FJEDERSKIVE MED LILLE UDVENDIG DIAM.

DIN 7980

UBEHANDLET, FZB

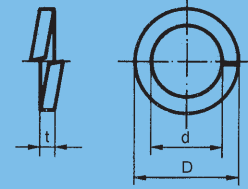

FOR SKRUE		d	D	t	PAKKEP.	PRIS PR. 100 STK.	
M-GEVIND	ENG/AM-GEVIND					UBEH	FZB
M3	1/8	3,1	5,6	1	1000	20:-	21:-
M4	5/32	4,1	7	1,2	1000	20:-	23:-
M5	3/16	5,1	8,8	1,6	1000	24:-	27:-
M6		6,1	9,9	1,6	1000	27:-	30:-
M8	5/16	8,1	12,7	2	500	47:-	54:-
M10		10,2	16	2,5	500	80:-	89:-
M12		12,2	18	2,5	200	83:-	101:-
M14		14,2	21,1	3	200	239:-	251:-
M16	5/8	16,2	24,4	3,5	200	177:-	243:-
M18		18,2	26,4	3,5	200	428:-	498:-
M20		20,2	30,6	4,5	100	369:-	459:-
M22	7/8	22,5	32,9	4,5	100	480:-	491:-
M24		24,5	35,9	5	100	521:-	593:-
M27		27,5	38,9	5	100	1070:-	1238:-
M30	1 1/8	30,5	44,1	6	50	1229:-	1610:-
M35		36,5	52,2	7	50	1791:-	2385:-

BEST.EX: DIN 7980 3,1 UBEHANDLET
DATA.EX: 7980031

SKIVE FOR STÅLKONSTRUKTIONER

DIN 6916 (~ISO 7416)

295-350 HV UBEHANDLET, FZB

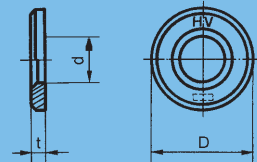

FOR SKRUE		d	D	t	PAKKEP.	PRIS PR. 100 STK.	
						UBEH	FZB
M12		13	24	3	100	290:-	330:-
M16		17	30	4	100	495:-	668:-
M20		21	37	4	100	590:-	776:-
M22		23	39	4	100	700:-	790:-
M24		25	44	4	100	895:-	1209:-
M27		28	50	5	50	1900:-	2100:-
M30		31	56	5	50	3567:-	3900:-
M33		34	60	5	50	6287:-	
M36		37	66	6	50	6900:-	

BEST.EX: DIN 6916 13 x 24 x 3 UBEHANDLET
DATA.EX: 691613

4-KANTSKIVE

DIN 436 (SS 1630)

100 HV UBEHANDLET, FZB, FZV

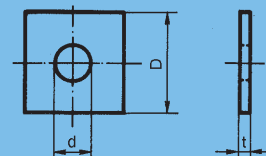

FOR SKRUE		d	D	t	PAKKEP.	PRIS PR. 100 STK.		
M-GEVIND	ENG/AM-GEVIND					UBEH	FZB	FZV
M6	1/4	7	20	2	100	221:-	190:-	270:-
M8	5/16	9	25	3	100	230:-	195:-	280:-
M10	3/8	11	30	3	100	275:-	220:-	320:-
M12	1/2	13,5	40	4	100	585:-	352:-	498:-
M16	5/8	17,5	50	5	50	1137:-	723:-	990:-
M20	3/4	22	60	5	50	1565:-	1315:-	1900:-
M22	7/8	24	70	6	50	2678:-	2412:-	3300:-
M24	1"	26	80	6	50	3420:-	2953:-	3950:-
M27		30	90	6	25	6300:-	8190:-	9828:-
M30	1 1/8	33	95	6	25	6863:-	8922:-	10707:-
	1 1/4	34	100	8	25	6920:-	8996:-	10793:-
M33		36	100	6	25	7650:-	9945:-	11934:-
M36	1 3/8	39	110	8	25	11475:-	14918:-	17902:-
M39	1 1/2	42	125	8	25	21150:-	27495:-	32994:-
M42		45	135	8	25	24750:-	32175:-	38610:-
M45	1 3/4	48	140	8	25	29700:-	38610:-	46332:-
M48		52	150	10	25	50400:-	65520:-	78624:-
M52		56	160	10	25	58500:-	76050:-	91260:-

BEST.EX: DIN 436 7 x 20 x 2 FZB
DATA.EX: 436071

*Bufab Danmark lagerfører 4-kantskiver i mange forskellige special mål. Spørg salgsafdelingen

STOR 4-KANTSKIVE

UBEHANDLET, FZB, FZV

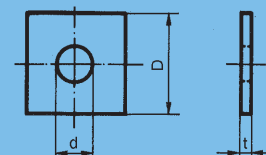

FOR SKRUE		d	D	t	PAKKEP.	PRIS PR. 100 STK.		
M-GEVIND	ENG/AM-GEVIND					UBEH	FZB	FZV
M12	1/2	14	50	4	100	840:-	1100:-	1500:-
M16	5/8	17,5	65	6	50	1650:-	2300:-	2950:-
M20	3/4	21	75	7	50	2500:-	3550:-	4600:-
M22	7/8	24	85	8	50	4050:-	5700:-	7250:-
M24	1"	27	100	8	25	5200:-	7450:-	10100:-

BEST.EX: STOR 4-KANTSKIVE 14 x 50 x 4 FZB
DATA.EX: 4BB1401

*Bufab Danmark lagerfører 4-kantskiver i mange forskellige special mål. Spørg salgsafdelingen

SIKRINGSSKIVER, AZ, IZ, AZV

DIN 6798

FJEDERSTÅL UBEHANDLET, FZB

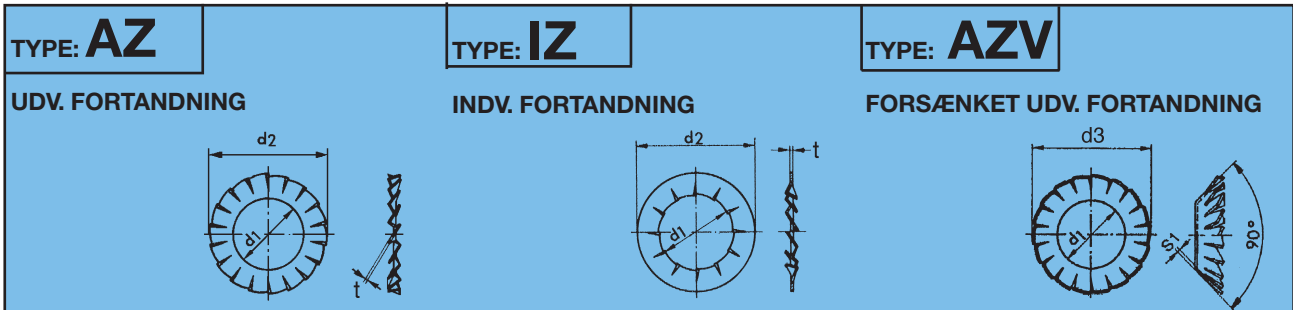

FOR SKRUE		d1	d2	d3	t	S1	PAKKEP.	PRIS PR. 100 STK.				
M-GEVIND	ENG/AM-GEVIND							AZ		IZ		AZV
								UBEH	FZB	UBEH	FZB	FZB
M2		2,2	4,5		0,3		8000	29:--	28:--	29:--	28:--	
M2,3		2,5	5		0,4		5000	29:--	28:--	29:--	28:--	
M2,5		2,7	5,5		0,4		4500	29:--	28:--	29:--	28:--	
M2,6		2,8	5,5		0,4		4000	29:--	28:--	29:--	28:--	
M3	1/8	3,2	6	6	0,4	0,2	4500	11:--	10:--	11:--	10:--	35:--
M3,5		3,7	7	7	0,5	0,25	2500	20:--	19:--	20:--	19:--	35:--
M4	5/32	4,3	8	8	0,5	0,25	2500	13:--	12:--	13:--	12:--	38:--
M5		5,1	9		0,5		1500	16:--	15:--	16:--	15:--	
M5	3/16	5,3	10	9,8	0,6	0,3	1200	17:--	16:--	17:--	16:--	43:--
M6	1/4	6,4	11	11,8	0,7	0,4	2000	20:--	19:--	20:--	19:--	52:--
M7		7,4	12,5		0,8		1250	59:--	53:--	59:--	53:--	
M8		8,2	14		0,8		1000	35:--	34:--	35:--	34:--	
M8	5/16	8,4	15	15,3	0,8	0,4	800	37:--	36:--	37:--	36:--	73:--
M10		10,5	18	19	0,9	0,5	1000	58:--	49:--	58:--	49:--	110:--
	7/16	11,5	19,5		0,9		800		128:--		128:--	
M12		13	20,5	23	1,0	0,5	700	85:--	79:--	85:--	79:--	220:--
	1/2	13,2	22		1,0		600		131:--		131:--	
M14		15	24	26,2	1,0	0,6	450	171:--	139:--	171:--	139:--	322:--
M16	5/8	17	26	30,2	1,2	0,6	500	201:--	176:--	201:--	176:--	
M18		19	30		1,4		350	320:--	290:--	320:--	290:--	
M20		21	33		1,4		250	480:--	359:--	480:--	359:--	
M22	7/8	23	36		1,5		200	610:--	460:--	610:--	460:--	
M24		25	38		1,5		150	860:--	654:--	860:--	654:--	
M27		28	44		1,6		120	1800:--	1156:--	1800:--	1156:--	
M30	1 1/8	31	48		1,6		100	2600:--	1900:--	2600:--	1900:--	

BEST.EX: DIN 6798 AZ 2,2 FZB

DATA.EX: AZ0221

SIKRINGSSKIVER AZ, IZ

DIN 6797

FJEDERSTÅL UBEHANDLET, FZB

TYPE: **AZ**

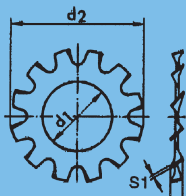

TYPE: **IZ**

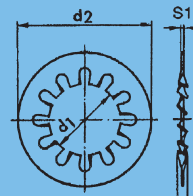

FOR SKRUE		d1	d2	S1	PAKKEP.	PRIS PR. 100 STK.			
M- GEVIND	ENG/AM- GEVIND					AZ		IZ	
						UBEH	FZB	UBEH	FZB
M2		2,2	4,5	0,3	1000	17:-	17:-	17:-	17:-
M2,3		2,5	5	0,4	1000	17:-	17:-	17:-	17:-
M2,5		2,7	5,5	0,4	1000	17:-	17:-	17:-	17:-
M2,6		2,8	5,5	0,4	1000	17:-	17:-	17:-	17:-
M3	1/8	3,2	6	0,4	1000	17:-	17:-	17:-	17:-
M3,5		3,7	7	0,5	1000	18:-	20:-	18:-	20:-
M4	5/32	4,3	8	0,5	1000	18:-	20:-	18:-	20:-
M5	3/16	5,3	10	0,6	1000	23:-	24:-	23:-	24:-
M6	1/4	6,4	11	0,7	500	26:-	27:-	26:-	27:-
M8	5/16	8,4	15	0,8	500	51:-	53:-	51:-	53:-
M10	3/8	10,5	18	0,9	200	81:-	83:-	81:-	83:-
M12		12,5	20,5	1,0	200	123:-	137:-	123:-	137:-
M14		14,5	24	1,0	200	174:-	203:-	174:-	203:-
M16	5/8	16,5	26	1,2	200	216:-	246:-	216:-	246:-
M18		19	30	1,4	100	372:-	410:-		410:-
M20		21	33	1,4	100	422:-	471:-	422:-	471:-

BEST.EX: DIN 6797 AZ 2,2 FZB

DATA.EX: 6797AZ0221

NORDLOCKSKIVER

CA 48 HRC GULKROM

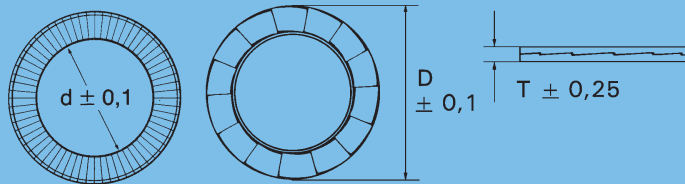

FOR SKRUE M-GEVIND ENG/AM-GEVIND	d	D	t	Mv	PAKKEP.	PRIS PR. 100 STK.	
						ULIMET	LIMET
M3	3,2	7,0	1,8	1,5	200	695:-	
M4	4,3	9,0	1,8	3,5	200	572:-	
M5	3/16	5,2	1,8	7,2	200	546:-	
M6	1/4	6,5	1,8	12	200	572:-	
M6*		6,5	2,6	13	200	845:-	1066:-
M8	5/16	8,2	2,6	30	200	604:-	799:-
M8*		8,6	2,6	32	200	994:-	936:-
M10	3/8	10,3	2,6	59	200	747:-	825:-
M10*		10,3	2,6	64	200	1553:-	1391:-
M12	1/2	13,0	2,6	103	200	1254:-	1352:-
M12*		13,0	3,7	110	100	2522:-	2301:-
M14	9/16	14,5	3,7	160	100	1963:-	2203:-
M16	5/8	17,0	3,7	250	100	1872:-	1989:-
M16*		17,0	4,0	260	100	3659:-	4108:-
M18		19,5	3,7	350	100	2567:-	3484:-
M20	3/4	21,0	3,7	490	100	2879:-	2886:-
M22	7/8	22,9	3,7	660	100	4563:-	4556:-
M24	1"	26,0	3,7	850	100	5817:-	5668:-
M27		28,5	4,6	1220	50	8573:-	
M30	1 1/8	30,5	4,6	1600	50	9412:-	
M33	1 1/4	33,5	4,6	2200	50	10549:-	
M36	1 3/8	36,6	4,6	2900	50	13320:-	
M39	1 1/2	39,5	4,6	3800	50	13988:-	

BEST.EX: NORDLOCKSKIVE M3 GK ULIMET **MV** = TILSPÆNDINGSMOMENT MED 8.8-SKRUER I Nm
DATA.EX: NLOCK033 * = SKIVE MED STOR YDDERDIAMETER

M5-M20 KAN LEVERES I SYREFAST UDFØRELSE

NORDLOCK-PRINCIPPET

NORDLOCK SKIVEN HAR SKÆVTSTILLEDE FLADER PÅ DEN ENE SIDE MED STØRRE STIGNING END SKRUEGENVINDEN, OG RADIALE TÆNDER PÅ DEN ANDEN SIDE. LÅSESKIVERNE MONTERES PARVIS MED FLADERNE MOD HINANDEN OG FÅR Derved DEN UNIKE NORDLOCK LÅSEEFFEKT.

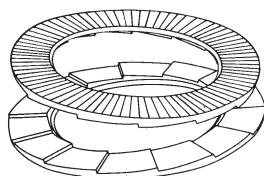

NÅR SKRUEGENVINDEN SPÆNDES GRIBER TÆNDERNE I GODS OG SKRUEGENVINDEN HVORVED EN SAMMEN KOPLING SKER. HVIS SKRUEGENVINDEN HAR TENDENS TIL AT LØSNE, TRÆKKE DEN ØVRE SKIVE MED OG TVINGES OP PÅ MODSATTE SKIVES SKRÅSTILLEDE FLADER. FORSPÆNDINGEN ØGES ISTEDET FOR AT MINDSKES PÅ GRUND AF KILEEFFEKTEN SOM OPSTÅR.

MONTERINGSEKSEMPEL

NORDLOCK SKIVEN KAN ANVENDES FOR BÅDE NORMALE SOM HÆRDEDE SKRUEGENVINDER SOM TILSPÆNDINGSMOMENT VÆLGES 20% HØJERE MOMENT END VED MONTERING MOD EN PLAN BLANK FORZINKET SKIVE.

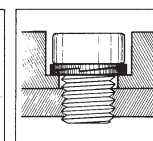
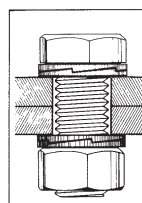
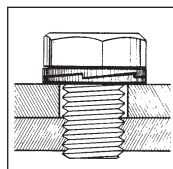
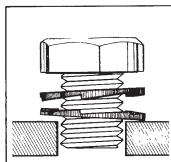

SKRUE I NEDSÆNKET HUL.

VED GENNEMGÅENDE HUL MONTERES MED NORDLOCK SKIVER BÅDE UNDER SKRUEHOVED OG MØTRIK.

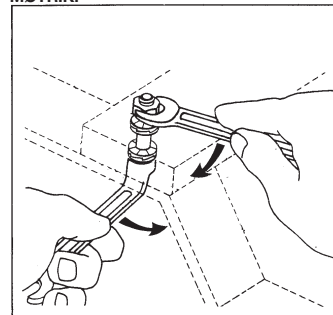

OBS ! LAV MODHOLD PÅ SKRUEGENVINDEN NÅR MØTRIKKEN TILSPÆNDES.

SCHNORRSKIVE

FJEDERSTÅL UBEHANDLET, FZB

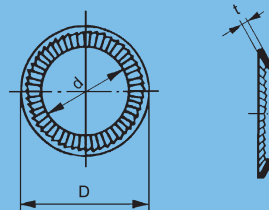

FOR SKRUE	d	D	t	PAKKEP.	PRIS PR. 100 STK.	
					UBEH	FZB
M1,6	1,7	3,2	0,35	500	33:-	
M2	2,2	4	0,35	500	33:-	43:-
M2,5	2,7	4,8	0,45	500	33:-	43:-
M3	3,2	5,5	0,45	500	33:-	43:-
M3,5	3,7	6	0,45	500	33:-	43:-
M4	4,3	7	0,5	250	36:-	47:-
M5	5,3	9	0,6	250	50:-	65:-
M6	6,4	10	0,7	250	57:-	75:-
M7	7,4	12	0,7	250	66:-	86:-
M8	8,4	13	0,8	250	77:-	101:-
M10	10,5	16	1,0	250	116:-	151:-
M12	13	18	1,1	100	156:-	
M14	15	22	1,2	100	215:-	
M16	17	24	1,3	100	270:-	
M18	19	27	1,5	100	528:-	
M20	21	30	1,5	100	614:-	
M22	23	33	1,5	100	713:-	
M24	25,6	36	1,8	100	983:-	
M27	28,6	39	2,0	100	1142:-	
M30	31,6	45	2,0	100	1580:-	

BEST.EX: SCHNORRSKIVE 1,7 x 3,2 x 0,35
DATA.EX: SCHNORR017

NITTESKIVE

UBEHANDLET, FZB

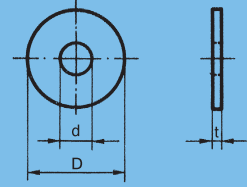

d	D	t	PAKKEPROGRAM	PRIS PR. 100 STK.	
				UBEH	FZB
3	13	1,0	200		28:-
4	16	1,0	200		30:-
5	13	1,0	200	25:-	22:-
5	16	1,0	200	25:-	25:-
5	19	1,0	200	30:-	29:-
5	22	1,0	200	48:-	49:-
5	25	1,0	200	55:-	58:-
6	16	1,0	200	28:-	28:-
6	19	1,0	200	33:-	29:-
6	22	1,5	200	48:-	49:-
6	25	1,5	200	60:-	58:-
8	16	1,5	200	100:-	89:-
8	19	1,5	200	40:-	46:-
8	22	1,5	200	45:-	49:-
8	25	1,5	200	60:-	58:-
10	19	1,5	200	70:-	75:-
10	22	1,5	200	65:-	75:-
10	25	1,5	200	110:-	79:-

BEST.EX: NITTESKIVE STÅL 3 x 13 x 1 FZB
DATA.EX: NB03131

Tolerance i.h.t DIN 522-C

SRKB KAROSSERISKIVE

UBEHANDLET, FZB

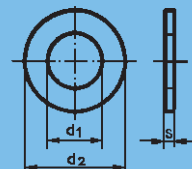

FOR SKRUE ENG/AM-GEVIND	d1	d2	s	PAKKEP.	PRIS PR. 100 STK.	
					UBEH	FZB
3/16	5,5	22	1,5	200	55:-	49:-
3/16	5,5	25	1,5	200	65:-	59:-
1/4	7	19	1,5	200	48:-	49:-
1/4	7	22	1,5	200	48:-	49:-
1/4	7	25	1,5	200	65:-	59:-
1/4	7	28	2,0	200	95:-	78:-
1/4	7	35	2,0	100	150:-	145:-
1/4	7	35	3,0	100	270:-	350:-
5/16	9	25	1,5	100		59:-
5/16	9	28	2,0	100	95:-	75:-
5/16	9	35	2,0	100	150:-	140:-
5/16	9	35	3,0	100	210:-	190:-
3/8	11	28	2,0	100	95:-	79:-
3/8	11	35	2,0	100	150:-	140:-
3/8	11	35	3,0	100	200:-	180:-
7/16	12,5	28	2,0	100	110:-	85:-
7/16	12,5	35	2,0	100	150:-	149:-
7/16	12,5	35	3,0	100	200:-	180:-
1/2	14	35	2,0	100	160:-	210:-
1/2	14	35	3,0	100	220:-	290:-
1/2	14	42	3,0	100	390:-	490:-
5/8	17,5	50	3,0	100	460:-	600:-
3/4	21	60	4,0	100	980:-	1250:-

BEST.EX: SKRB 5,5 x 22 x 1,5 FZB
DATA.EX: SKRB05522151

Tolerance i.h.t DIN 522-C

FJEDERSKIVER

DIN 128 A OG B

FJEDERSTÅL UBEHANDLET, FZB

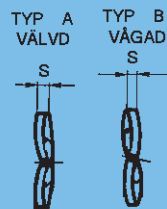

FOR SKRUE M- ENG/AM- GEVIND GEVIND		d1	d2	s	PAKKEP.	PRIS PR. 100 STK.			
						AU		B	
						UBEH	FZB	UBEH	FZB
M2		2,1	4,4	0,5	1000		23:-		23:-
M2,3		2,4	4,9	0,6	1000		23:-		23:-
M2,5		2,6	5,1	0,6	1000		23:-		23:-
M2,6		2,7	5,2	0,6	1000		23:-		23:-
M3	1/8	3,1	6,2	0,7	1000	24:-	27:-	24:-	27:-
M4	5/32	4,1	7,6	0,8	1000	29:-	32:-	29:-	32:-
M5	3/16	5,1	9,2	1,0	1000	35:-	41:-	35:-	41:-
M6		6,1	11,8	1,3	1000	50:-	68:-	50:-	68:-
M8		8,2	14,9	1,6	1000	80:-	116:-	80:-	116:-
M10		10,2	18,1	1,8	1000	116:-	170:-	116:-	170:-
M12		12,2	21,1	2,1	500	174:-	248:-	174:-	248:-
M14		14,2	24,1	2,4	500	284:-	401:-	284:-	401:-
M16	5/8	16,2	27,4	2,8	250	359:-	536:-	359:-	536:-
M18		18,2	29,4	2,8	250	381:-	585:-	381:-	585:-
M20	3/4	20,2	33,6	3,2	100	575:-	878:-	575:-	878:-
M22	7/8	22,5	35,9	3,2	100	653:-	980:-	653:-	980:-
M24		24,5	40,0	4,0	100	968:-	1508:-	968:-	1508:-
M27		27,5	43,0	4,0	100	1013:-	1530:-	1013:-	1530:-
M30		30,5	48,2	6,0	50	2228:-	3308:-	2228:-	3308:-

BEST.EX: DIN 128 A 2,1 FZB

DATA.EX: 128A0211

FJEDERSKIVE

DIN 137 A

FJEDERSTÅL UBEHANDLET, FZB

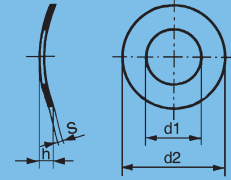

FOR SKRUE		d1	d2	h min	s	PAKKEP.	PRIS PR. 100 STK.	
M-GEVIND	ENG/AM-GEVIND						UBEH	FZB
M1		1,1	2,5	0,35	0,2	1000	17:--	17:--
M2		1,3	3	0,35	0,2	1000	17:--	17:--
M1,4		1,5	3	0,4	0,25	1000	17:--	17:--
M1,7		1,8	4	0,45	0,25	1000	17:--	17:--
M2		2,2	4,5	0,5	1,3	1000	17:--	17:--
M2,3		2,5	5	0,5	1,3	1000	17:--	17:--
M2,6		2,8	5,5	0,55	0,3	1000	17:--	17:--
M3	1/8	3,2	6	0,65	0,4	1000	17:--	17:--
M3,5		3,7	7	0,7	0,4	1000	18:--	20:--
M4	5/32	4,3	8	0,8	0,5	1000	18:--	20:--
M5		5,3	10	0,9	0,5	1000	26:--	25:--
M6	1/4	6,4	11	1,1	0,5	1000	26:--	25:--
M7		7,4	12	1,2	0,5	1000	27:--	29:--
M8	5/16	8,4	15	1,7	0,5	1000	50:--	49:--
M10	3/8	10,5	18	2,0	0,8	1000	105:--	99:--

BEST.EX: DIN 137 A 1,1 FZB
DATA.EX: 137A0111

FJEDERSKIVE

DIN 137 B

FJEDERSTÅL UBEHANDLET, FZB

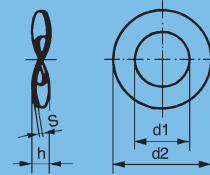

FOR SKRUE		d1	d2	h min	s	PAKKEP.	PRIS PR. 100 STK.	
M-GEVIND	ENG/AM-GEVIND						UBEH	FZB
M3	1/8	3,2	8	0,8	0,5	1000	20:--	25:--
M3,5		3,7	8	0,9	0,5	1000	23:--	26:--
M4	5/32	4,3	9	1,0	0,5	1000	20:--	26:--
M5		5,3	11	1,1	0,5	1000	30:--	36:--
M6	1/4	6,4	12	1,3	0,5	1000	30:--	39:--
M7		7,4	14	1,5	0,8	1000	83:--	101:--
M8	5/16	8,4	15	1,5	0,8	1000	56:--	66:--
M10	3/8	10,5	21	2,1	1	1000	110:--	135:--
M12	1/2	13	24	2,5	1,5	500	243:--	
M14		15	28	3,1	1,6	500	368:--	473:--
M16	5/8	17	30	3,2	1,6	250	408:--	443:--
M18		19	34	3,3	1,6	250	521:--	671:--
M20	3/4	21	36	3,7	1,6	100	567:--	684:--
M22	7/8	23	40	3,9	1,8	100	1206:--	1278:--
M24		25	44	4,1	1,8	100	1598:--	1980:--
M27		28	50	4,7	2,0	100	2318:--	2903:--
M30	1 1/8	31	56	5,0	2,2	100	4343:--	5153:--

BEST.EX: DIN 137 B 3,2 FZB
DATA.EX: 137B0321

TALLERKENFJEDERSKIVE

DIN 2093 (SMS 2313)
FJEDERSTÅL



DIMENSION	PRIS PR. 100 STK.	DIMENSION	PRIS PR. 100 STK.
8 x 3,2 x 0,3	308:--	15 x 8,2 x 0,7	407:--
0,4	314:--	0,8	424:--
0,5	322:--		
*8 x 4,2 x 0,2	308:--	*16 x 8,2 x 0,4	396:--
*0,3	308:--	0,6	411:--
*0,4	314:--	*0,8	445:--
		*0,9	445:--
10 x 3,2 x 0,3	325:--	18 x 6,2 x 0,4	413:--
0,4	337:--	0,5	420:--
0,5	338:--	0,6	426:--
		0,7	430:--
10 x 4,2 x 0,4	337:--	0,8	445:--
0,5	339:--		
0,6	340:--	18 x 8,2 x 0,6	430:--
		0,7	430:--
*10 x 5,2 x 0,25	337:--	0,8	445:--
*0,4	337:--	1,0	494:--
*0,5	339:--		
12 x 4,2 x 0,4	367:--	*18 x 9,2 x 0,7	430:--
0,5	369:--	*1,0	494:--
0,6	373:--		
		20 x 8,2 x 0,5	441:--
12 x 5,2 x 0,5	369:--	0,6	449:--
0,6	373:--	0,7	460:--
		0,8	470:--
12 x 6,2 x 0,5	369:--	0,9	485:--
0,6	373:--	1,0	532:--
*12,5 x 6,2 x 0,35	369:--	20 x 10,2 x 0,4	434:--
*0,5	369:--	*0,5	443:--
*0,7	369:--	*0,8	470:--
		0,9	485:--
*14 x 7,2 x 0,35	382:--	1,0	532:--
*0,5	382:--	*1,1	551:--
*0,8	417:--		
15 x 5,2 x 0,4	382:--	*22,5 x 11,2 x 0,6	462:--
0,5	396:--	*0,8	513:--
0,6	403:--	*1,25	1216:--
0,7	407:--		
		23 x 8,2 x 0,7	485:--
15 x 6,2 x 0,4	396:--	0,8	523:--
0,5	396:--	0,9	532:--
0,6	403:--		
0,7	407:--	23 x 10,2 x 0,9	532:--
		1,0	627:--
		1,25	690:--

BEST.EX: DIN 2093 STÅL 8 x 3,2 x 0,3
DATA.EX: 0320803

*Mål kan afvige fra DIN 2093

TALLERKENFJEDERSKIVE

DIN 2093 (SMS 2313)
FJEDERSTÅL



DIMENSION	PRIS PR. 100 STK.	DIMENSION	PRIS PR. 100 STK.
23 x 12,2 x 1,0	627:-	40 x 16,3 x 1,5	2603:-
1,25	1235:-	1,75	2755:-
1,5	1330:-	2,0	2774:-
*25 x 12,2 x 0,7	532:-	40 x 18,3 x 2,0	1900:-
*0,9	580:-	*40 x 20,4 x 1,0	1235:-
1,0	790:-	*1,5	2603:-
1,25	960:-	2,0	2774:-
*1,5	1387:-	*2,25	3078:-
28 x 10,2 x 0,8	656:-	2,5	3344:-
1,0	694:-	*45 x 22,4 x 1,25	3249:-
1,25	1425:-	*1,75	3591:-
1,5	1520:-	*2,5	3971:-
28 x 12,2 x 1,0	694:-	48 x 16,3 x 1,5	3515:-
1,25	1425:-	50 x 18,4 x 1,25	3439:-
1,5	1520:-	1,5	3572:-
*28 x 14,2 x 0,8	656:-	2,0	4275:-
*1,0	694:-	2,5	5035:-
1,25	1425:-	3,0	5795:-
*1,5	1520:-	50 x 20,4 x 2,0	4275:-
*31,5 x 16,3 x 0,8	732:-	2,5	5035:-
*1,25	1577:-	50 x 22,4 x 2,0	4275:-
1,5	1691:-	2,5	5035:-
*1,75	1805:-	*50 x 25,4 x 1,25	3439:-
2,0	2014:-	1,5	3211:-
34 x 12,3 x 1,0	808:-	*2,0	4275:-
1,25	1710:-	2,25	4617:-
1,5	1938:-	2,5	5035:-
34 x 14,3 x 1,25	1710:-	*3,0	5795:-
1,5	1938:-	*56 x 28,5 x 1,5	4351:-
34 x 16,3 x 1,5	1938:-	*2,0	5130:-
2,0	2128:-	2,5	6175:-
*35,5 x 18,3 x 0,9	855:-	*3,0	7125:-
*1,25	1691:-	60 x 20,5 x 2,0	5795:-
*2,0	2337:-	2,5	6650:-
40 x 14,3 x 1,25	2413:-	3,0	7790:-
1,5	2603:-		
1,75	2755:-		
2,0	2774:-		

BEST.EX: DIN 2093 STÅL 23 x 12,2 x 1,0
DATA.EX: 1222310

*Mål kan afvige fra DIN 2093

TALLERKENFJEDERSKIVE

DIN 2093 (SMS 2313)

FJEDERSTÅL



DIMENSION	PRIS PR. 100 STK.	DIMENSION	PRIS PR. 100 STK.
60 x 25,5 x 2,5 3,0	6650:- 7885:-	*90 x 46 x 2,5 *3,5 *5,0	15960:- 18620:- 28500:-
60 x 30,5 x 2,5 2,75 3,0 3,5	6650:- 7220:- 7885:- 8740:-	100 x 41 x 4,0 5,0	28120:- 35150:-
*63 x 31 x 1,8 *2,5 3,0 *3,5	6460:- 7125:- 8645:- 9405:-	*100 x 51 x 2,7 *3,5 4,0 5,0 *6,0 7,0	20140:- 22420:- 28120:- 35150:- 45410:- 64600:-
70 x 24,5 x 3,0 3,5	11020:- 12730:-	*112 x 57 x 3,0 *4,0 *6,0	31350:- 35910:- 50350:-
70 x 25,5 x 2,0	8740:-	125 x 51 x 4,0 5,0 6,0	42750:- 49400:- 69350:-
70 x 30,5 x 2,5 3,0	9405:- 11020:-	125 x 61 x 5,0 6,0 8,0	49400:- 69350:- 96900:-
70 x 35,5 x 3,0 3,5 4,0	11020:- 12730:- 15770:-	*125 x 64 x 3,5 *5,0 6,0 7,0 8,0	36480:- 49400:- 69350:- 88350:- 96900:-
70 x 40,5 x 4,0 5,0	15770:- 19760:-	125 x 71 x 6,0 8,0 10,0	69350:- 96900:- 112100:-
*71 x 36 x 2,0 *2,5 *4,0	8835:- 10070:- 15960:-	*140 x 72 x 3,8 *5,0 *8,0	54150:- 70300:- 121600:-
80 x 30,5 x 2,5	12160:-	150 x 61 x 5,0 6,0 7,0	76950:- 102600:- 121600:-
80 x 31 x 3,0 4,0	13490:- 19570:-		
80 x 36 x 3,0	13490:-		
*80 x 41 x 3,0 4,0 *5,0	13490:- 19570:- 23750:-		

BEST.EX: DIN 2093 STÅL 60 x 25,5 x 2,5
DATA.EX: 2556025

*Mål kan afvige fra DIN 2093

SKRÅSKIVE

DIN 434 (SMS 93)

100-250 HV UBEHANDLET, FZB, FZV

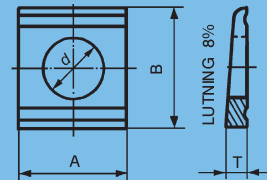

FOR SKRUE		d	A	B	T	PRIS PR. 100 STK.		
M-GEVIND	ENG/AM-GEVIND					UBEH	FZB	FZV
M8	5/16	9	22	22	3,8	455:-	509:-	648:-
M10	3/8	11	22	22	3,8	455:-	558:-	690:-
M12	1/2	14	26	30	4,9	621:-	689:-	750:-
M16	5/8	18	32	36	5,9	824:-	980:-	1100:-
M20	3/4	22	40	44	7,0	1436:-	1668:-	1900:-
M22	7/8	24	44	50	8,0	2793:-	3375:-	3680:-
M24	1"	26	56	56	8,5	4055:-	4163:-	4400:-
M30	1 1/8	33	62	62	9,0	5930:-	6975:-	7365:-

BEST.EX: DIN 434 9 UBEHANDLET
DATA.EX: 43409

PAKKEPROGRAM

STK.	M8-M12	M16-M20	M22-M24	M30
	1000	500	200	100

SKIVE

DIN 433

min.HV 140 UBEHANDLET, FZB

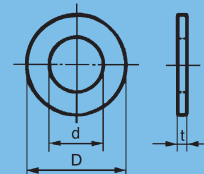

FOR SKRUE M-GEVIND	DIMENSION	PAKKEPROGRAM	PRIS PR. 100 STK.	
			UBEH	FZB
M2	2,2 x 4,5 x 0,3	5000	9:-	9:-
M2,5	2,7 x 5 x 0,5	5000	9:-	9:-
M3	3,2 x 6 x 0,5	5000	8:-	8:-
M3,5	3,7 x 7 x 0,5	5000	27:-	12:-
M4	4,3 x 8 x 0,5	5000	8:-	9:-
M5	5,3 x 9 x 1	5000	15:-	18:-
M6	6,4 x 11 x 1,6	1000	27:-	33:-
M8	8,4 x 15 x 1,6	1000	48:-	62:-
M10	10,5 x 18 x 1,6	1000	74:-	90:-
M12	13 x 20 x 2	1000	116:-	138:-
M14	15 x 24 x 2,5	500	167:-	201:-
M16	17 x 28 x 2,5	500	215:-	257:-
M18	19 x 30 x 2,5	500	320:-	387:-
M20	21 x 34 x 3,0	500	383:-	464:-

BEST.EX: DIN 433 2,2 x 4,5 x 0,5 UBEHANDLET
DATA.EX: 433022

SKIVE

DIN 126 (~ISO 7091)

min.HV 100 UBEHANDLET, FZB, FZV

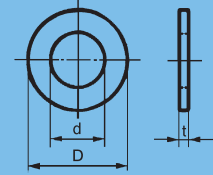

DIMENSION	PAKKEPROGRAM	PRIS PR. 100 STK.		
		UBEH	FZB	FZV
5,5 x 10 x 1	1000	24:--	26:--	
6,6 x 12 x 1,6	1000	26:--	33:--	
9 x 16 x 1,6	1000	48:--	62:--	77:--
11 x 20 x 2	1000	71:--	98:--	122:--
13,5 x 24 x 2,5	500	101:--	138:--	174:--
17,5 x 30 x 3	500	147:--	216:--	
22 x 37 x 3	500	242:--	347:--	435:--
24 x 39 x 3	100	306:--	419:--	
26 x 44 x 4	100	383:--	585:--	690:--
30 x 50 x 4	100	576:--	828:--	
33 x 56 x 4	100	693:--	1026:--	
36 x 60 x 5	100	1044:--	1512:--	
39 x 66 x 5	100	1332:--	1890:--	
42 x 72 x 6	50	1584:--	2412:--	
45 x 78 x 7	50	2520:--	3654:--	
48 x 85 x 7	50	2880:--	4266:--	
52 x 92 x 8	25	3600:--	5490:--	
56 x 98 x 8	25	7560:--	9720:--	
62 x 105 x 9	25	10980:--	13500:--	
66 x 110 x 9	25	12060:--	14760:--	
70 x 115 x 9	25	12960:--	16020:--	
78 x 125 x 10	25	16920:--	20700:--	
86 x 140 x 12	25	27000:--	32940:--	

BEST.EX: DIN 126 5,5 x 10 x 1 FZB

DATA.EX: 1260551

PASSKIVE

DIN 988-S

FJEDERSTÅL 440-500 HV UBEHANDLET

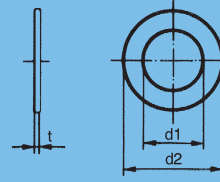

d1	d2	t	PAKKEP.	PRIS PR. 100 STK.	d1	d2t	t	PAKKEP.	PRIS PR. 100 STK.
3	6	1	2500	188:-	45	55	3	50	5170:-
4	8	1	2500	204:-	45	56	3	50	5670:-
6	12	1,2	1000	240:-	48	60	3	50	6338:-
8	14	1,2	1000	267:-	50	62	3	50	6338:-
9	15	1,2	1000	301:-	50	63	3	50	6338:-
10	16	1,2	1000	302:-	52	65	3	50	7338:-
12	18	1,2	1000	321:-	55	68	3	50	7338:-
13	19	1,5	1000	565:-	56	70	3	50	8005:-
14	20	1,5	1000	524:-	56	72	3	50	8339:-
15	21	1,5	1000	559:-	60	75	3	50	9006:-
15	22	1,5	1000	568:-	63	80	3	50	11007:-
16	22	1,5	1000	522:-	65	85	3,5	50	16346:-
17	24	1,5	1000	552:-	70	90	3,5	50	16346:-
18	25	1,5	500	620:-	75	95	3,5	50	17680:-
19	26	1,5	500	733:-	80	100	3,5	50	17680:-
20	28	2	500	1268:-	85	105	3,5	50	21350:-
22	30	2	500	1717:-	90	110	3,5	50	21350:-
22	32	2	250	1502:-	95	115	3,5	50	24682:-
25	35	2	250	1602:-	100	120	3,5	50	25016:-
25	36	2	250	1835:-	100	125	3,5	50	35373:-
26	37	2	250	2002:-	105	130	3,5	50	41478:-
28	40	2	250	2335:-	120	150	3,5	50	49660:-
30	42	2,5	50	3169:-	140	170	3,5	50	51045:-
30	50	2,5	50	3900:-	160	190	0,3	50	66000:-
32	45	2,5	50	3503:-	160	190	3,5	50	67378:-
35	45	2,5	50	3503:-	170	200	3,5	50	70336:-
36	45	2,5	50	4335:-					
37	47	2,5	50	3503:-					
40	50	2,5	50	4003:-					
42	52	2,5	50	4003:-					

BEST.EX: DIN 988-S 3 x 6 x 1 UBEHANDLET
 DATA.EX: 988S030610

PASSKIVE

DIN 988

UBEHANDLET

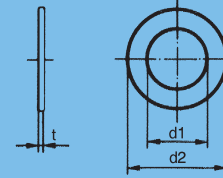

d1	d2	t	PAKKEP.	PRIS PR. 100 STK.	d1	d2	t	PAKKEP.	PRIS PR. 100 STK.
3	6	0,1	5000	132:–	11	17	0,1	2000	210:–
3	6	0,2	5000	140:–	11	17	0,2	2000	220:–
3	6	0,3	5000	150:–	11	17	0,3	2000	230:–
3	6	0,5	5000	161:–	11	17	0,5	1000	260:–
3	6	1,0	5000	192:–	11	17	1,0	5000	298:–
4	8	0,1	5000	124:–	12	18	0,1	2000	170:–
4	8	0,2	5000	147:–	12	18	0,2	2000	178:–
4	8	0,3	5000	149:–	12	18	0,3	2000	188:–
4	8	0,5	5000	149:–	12	18	0,5	1000	197:–
4	8	1,0	5000	181:–	12	18	1,0	5000	264:–
5	10	0,1	5000	147:–	12	18	1,2	2000	289:–
5	10	0,2	2500	134:–	12	24	0,5	2000	310:–
5	10	0,3	2500	157:–	13	19	0,1	2000	315:–
5	10	0,5	2500	159:–	13	19	0,2	1000	285:–
5	10	1,0	2500	192:–	13	19	0,3	5000	234:–
6	12	0,1	5000	133:–	13	19	0,5	2000	286:–
6	12	0,2	2000	139:–	13	19	1,0	2000	298:–
6	12	0,3	2000	149:–	13	19	1,5	2000	635:–
6	12	0,5	2000	162:–	14	20	0,1	1000	310:–
6	12	1,0	1000	202:–	14	20	0,2	2000	320:–
7	13	0,1	5000	157:–	14	20	0,3	2000	502:–
7	13	0,2	2000	172:–	14	20	0,5	2000	225:–
7	13	0,3	2000	181:–	14	20	1,0	2000	310:–
7	13	0,5	2000	172:–	14	26	0,1	1000	990:–
7	13	1,0	1000	255:–	14	26	0,2	1000	990:–
8	14	0,1	5000	145:–	15	21	0,1	2000	206:–
8	14	0,2	2000	154:–	15	21	0,2	2000	226:–
8	14	0,25	2000	160:–	15	21	0,3	2000	230:–
8	14	0,3	2000	162:–	15	21	0,5	1000	237:–
8	14	0,5	2000	165:–	15	21	1,0	1000	330:–
8	14	1,0	1000	208:–	15	22	0,1	1000	215:–
9	15	0,1	5000	175:–	15	22	0,2	1000	234:–
9	15	0,5	2000	215:–	15	22	0,3	1000	255:–
10	16	0,1	5000	157:–	15	22	0,5	1000	239:–
10	16	0,2	2000	170:–	15	22	1,0	1000	343:–
10	16	0,3	2000	174:–	15	22	1,5	1000	590:–
10	16	0,5	2000	189:–					
10	16	1,0	1000	232:–					
10	16	1,2	1000	249:–					

BEST.EX: DIN 988 3 x 6 x 0,1 UBEHANDLET
DATA.EX: 988030601

PASSKIVE

DIN 988

UBEHANDLET

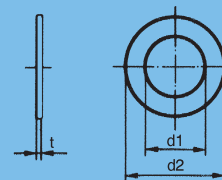

d1	d2	t	PAKKEP.	PRIS PR. 100 STK.	d1	d2	t	PAKKEP.	PRIS PR. 100 STK.
16	22	0,1	2000	216:–	25	36	0,2	1000	450:–
16	22	0,15	2000	390:–	25	36	1,0	500	733:–
16	22	0,2	2000	235:–	26	37	0,1	1000	275:–
16	22	0,3	2000	252:–	26	37	0,2	1000	316:–
16	22	0,5	1000	243:–	26	37	0,5	500	453:–
16	22	1,0	1000	337:–	26	37	1,0	500	634:–
17	24	0,1	2000	223:–	28	40	0,1	1000	297:–
17	24	0,2	2000	217:–	28	40	0,2	1000	529:–
17	24	0,3	1000	237:–	28	40	0,3	1000	407:–
17	24	0,5	1000	270:–	28	40	0,5	500	468:–
17	24	1,0	1000	388:–	28	40	1,0	500	754:–
17	24	1,5	1000	640:–	30	42	0,1	1000	318:–
18	25	0,1	2000	230:–	30	42	0,2	1000	384:–
18	25	0,2	2000	249:–	30	42	0,3	1000	418:–
18	25	0,3	1000	275:–	30	42	0,5	500	516:–
18	25	0,5	1000	307:–	30	42	1,0	500	722:–
18	25	1,0	1000	398:–	30	42	2,5	500	2900:–
19	26	0,1	2000	243:–	32	45	0,1	1000	650:–
19	26	0,2	2000	410:–	32	45	0,2	1000	615:–
19	26	0,3	1000	282:–	32	45	0,3	1000	444:–
19	26	0,5	1000	327:–	32	45	0,5	500	627:–
19	26	1,0	500	409:–	32	45	1,0	250	857:–
20	28	0,1	2000	250:–	35	45	0,1	250	331:–
20	28	0,2	1000	230:–	35	45	0,2	250	418:–
20	28	0,3	1000	249:–	35	45	0,3	250	427:–
20	28	0,5	1000	293:–	35	45	0,5	250	551:–
20	28	1,0	500	397:–	35	45	1,0	250	785:–
20	28	2,0	500	875:–	35	45	2,0	250	2466:–
22	30	0,1	2000	316:–	35	45	2,5	250	2610:–
22	30	0,2	1000	560:–	36	45	0,1	1000	320:–
22	30	0,3	1000	590:–	36	45	0,2	500	350:–
22	30	0,5	1000	390:–	36	45	0,3	500	390:–
22	30	1,0	500	596:–	36	45	0,5	500	626:–
22	32	0,1	2000	284:–	36	45	1,0	500	690:–
22	32	0,2	1000	318:–	37	47	0,1	500	331:–
22	32	0,3	1000	338:–	37	47	0,2	500	411:–
22	32	0,5	1000	363:–	37	47	0,3	500	434:–
22	32	1,0	500	554:–	37	47	0,5	500	558:–
22	32	2,0	500	1410:–	37	47	1,0	500	789:–
25	35	0,1	2000	254:–	40	50	0,1	500	464:–
25	35	0,2	1000	304:–	40	50	0,2	500	564:–
25	35	0,3	1000	331:–	40	50	0,3	500	567:–
25	35	0,5	1000	377:–	40	50	0,5	500	718:–
25	35	1,0	500	559:–	40	50	1,0	500	977:–
25	35	2,0	500	990:–	40	50	1,5	500	2891:–
					40	50	2,0	500	3188:–
					40	50	2,5	500	5200:–

BEST.EX: DIN 988 16 x 22 x 0,1 UBEHANDLET

DATA.EX: 988162201

PASSKIVE

DIN 988

UBEHANDLET

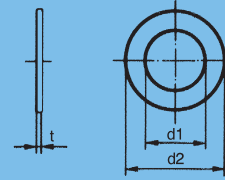

d1	d2	t	PAKKEP.	PRIS PR. 100 STK.	d1	d2	t	PAKKEP.	PRIS PR. 100 STK.
42	52	0,1	100	484:-	65	85	0,25	50	1900:-
42	50	0,2	100	550:-	65	85	0,3	50	1950:-
42	52	0,3	100	551:-	65	85	1,0	50	2846:-
42	52	0,5	100	718:-	65	85	3,5	50	9900:-
42	52	1,0	100	1082:-	70	85	0,1	50	3600:-
42	52	1,5	100	1400:-	70	85	0,3	50	3900:-
45	55	0,1	100	484:-	70	85	0,5	50	4600:-
45	55	0,3	100	601:-	70	90	0,3	50	1678:-
45	55	0,5	100	785:-	70	90	0,5	50	1804:-
45	55	1,0	100	1112:-	70	90	1,0	50	2925:-
45	55	3,0	100	3900:-	70	90	1,5	50	6695:-
48	55	2,0	100	6400:-	75	90	0,3	50	4600:-
48	60	0,3	100	960:-	75	90	0,5	50	8400:-
48	60	0,5	100	979:-	75	95	0,1	50	1302:-
48	60	1,0	100	3800:-	75	95	0,3	50	2076:-
48	60	1,5	100	4069:-	75	95	1,0	50	3901:-
50	62	0,1	100	518:-	80	100	0,1	50	1268:-
50	62	0,2	100	801:-	80	100	0,2	50	1550:-
50	62	0,3	100	664:-	80	100	0,3	50	1879:-
50	62	0,5	100	896:-	80	100	0,5	50	2388:-
50	62	1,0	100	1360:-	80	100	1,0	50	4028:-
52	65	1,0	100	1976:-	85	105	0,3	50	2003:-
52	65	2,0	100	5362:-	85	105	0,5	50	3062:-
55	68	0,1	100	685:-	90	110	0,1	50	1286:-
55	68	0,3	100	1033:-	90	110	0,2	50	1898:-
55	68	1,0	100	1752:-	90	110	0,3	50	2045:-
56	70	1,0	100	803:-	90	110	0,5	50	2593:-
56	72	0,1	100	803:-	90	110	1,0	50	4451:-
56	72	0,3	100	1102:-	90	110	3,5	50	19000:-
56	72	1,0	100	2031:-	95	110	0,1	50	12100:-
60	75	0,1	100	877:-	95	110	0,3	50	14600:-
60	72	0,2	100	1275:-	95	110	0,5	50	16200:-
60	75	0,3	100	1450:-	95	115	0,1	50	2297:-
60	75	0,5	100	1531:-	95	115	0,15	50	2400:-
60	75	1,0	100	2478:-	95	115	0,2	50	2600:-
60	75	2,0	100	7146:-	95	115	0,3	50	2700:-
60	75	3,0	100	9400:-	100	120	1,0	25	5015:-
63	80	0,1	50	909:-	100	125	1,0	25	7580:-
63	80	0,2	50	1297:-	105	130	0,5	25	4543:-
63	80	0,3	50	1338:-	110	130	0,3	25	11500:-
63	80	0,5	50	1611:-	110	140	0,3	25	5843:-
63	80	1,0	50	2454:-	110	140	0,5	25	7956:-
63	80	2,0	50	7044:-	120	150	0,1	25	4787:-
65	80	0,1	50	1068:-	120	150	0,2	25	6327:-
65	80	0,3	50	1700:-	185	215	0,3	25	14700:-
65	80	0,5	50	1711:-	220	250	0,5	25	23500:-
65	85	0,15	50	1510:-					
65	85	0,2	50	1511:-					

BEST.EX: DIN 988 42 x 52 x 0,1 UBEHANDLET

DATA.EX: 988425201

SKIVE

DIN 1440 (~ISO 8738)

UBEHANDLET/FZB

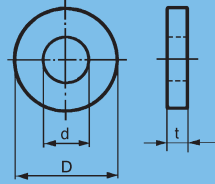

d	D	t	PAKKEPROGRAM	PRIS PR. 100 STK.	
				UBEH	FZB
4	8	0,8	1000	65:-	66:-
5	10	0,8	1000	74:-	78:-
6	12	1,6	1000	110:-	120:-
7	14	1,6	1000	152:-	165:-
8	16	2	1000	203:-	224:-
10	20	2,5	1000	264:-	306:-
12	25	3	500	387:-	468:-
13	25	3	500	387:-	467:-
14	28	3	500	468:-	575:-
16	28	3	500	468:-	558:-
18	30	4	200	698:-	833:-
20	32	4	200	833:-	968:-
22	34	4	200	945:-	1103:-
23	36	4	200	990:-	1170:-
25	40	4	200	1238:-	1463:-
26	40	5	100	1755:-	2026:-
28	42	5	100	1980:-	2250:-
30	45	5	100	2205:-	2565:-
32	50	5	100	2948:-	3353:-
33	50	5	100	3105:-	3465:-
35	52	6	100	3915:-	4343:-
36	52	6	100	3915:-	4320:-
40	58	6	50	4590:-	5108:-
45	62	7	50	5580:-	6300:-
50	68	8	50	8888:-	9675:-
55	75	9	LØSE	18900:-	20025:-
60	80	9	LØSE	21600:-	22725:-
65	90	9	LØSE	32850:-	34650:-
70	95	10	LØSE	41850:-	43875:-
75	100	10	LØSE	50400:-	52650:-
80	110	12	LØSE	76500:-	79875:-
85	110	12	LØSE	76500:-	78750:-
90	115	12	LØSE	76500:-	79875:-
95	120	12	LØSE	85500:-	87750:-
100	125	14	LØSE	97875:-	101250:-

BEST.EX: DIN 1440 4 x 8 x 0,8 FZB

DATA.EX: 1440041

SKIVE

DIN 1441

UBEHANDLET/FZB

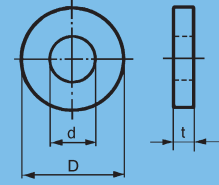

d	D	t	PAKKEPROGRAM	PRIS PR. 100 STK.	
				UBEH	FZB
5,5	10	0,8	1000	41:-	44:-
7	12	1,6	1000	47:-	54:-
8	14	1,6	1000	62:-	72:-
9	16	2	1000	81:-	98:-
11	20	2,5	500	126:-	161:-
13	25	3	500	192:-	260:-
14	25	3	500	194:-	257:-
15	28	3	500	230:-	314:-
17	28	3	500	252:-	327:-
19	30	4	200	342:-	450:-
21	32	4	200	405:-	522:-
23	34	4	200	630:-	585:-
24	36	4	200	513:-	665:-
25	38	4	200	630:-	788:-
26	40	4	200	720:-	912:-
27	40	5	100	878:-	1092:-
28	40	5	100	912:-	1115:-
29	42	5	100	990:-	1215:-
31	45	5	100	1125:-	1395:-
34	50	5	100	1463:-	1823:-
37	52	6	100	1755:-	2160:-
41	58	6	50	2340:-	2835:-
46	62	7	50	2970:-	3555:-
51	68	8	50	4275:-	5063:-
56	75	9	LØSE	9450:-	10575:-
62	80	9	LØSE	10575:-	11700:-
68	90	9	LØSE	14400:-	15975:-
72	95	10	LØSE	17325:-	19350:-
78	100	10	LØSE	19125:-	21150:-
82	110	12	LØSE	27900:-	31275:-
86	110	12	LØSE	28800:-	31725:-
92	115	12	LØSE	30150:-	33075:-
98	120	12	LØSE	32850:-	35775:-
102	125	14	LØSE	41850:-	45675:-

BEST.EX: DIN 1441 5,5 x 10 x 0,8 FZB
DATA.EX: 144105510081

SKIVE FOR STÅLKONSTRUKTION

DIN 7989 A

UBEHANDLET, FZB, FZV

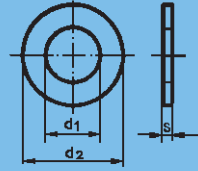

FOR SKRUE	d1	d2	t	PAKKEP.	PRIS PR. 100 STK.		
					UBEH	FZB	FZV
M10	11	21	8	100	405:-	441:-	473:-
M12	14	24	8	100	410:-	507:-	536:-
M16	18	30	8	100	579:-	674:-	716:-
M20	22	37	8	100	723:-	891:-	959:-
M22	24	39	8	100	891:-	1331:-	1547:-
M24	26	44	8	100	999:-	1404:-	1565:-
M27	30	50	8	50	1607:-	1877:-	2222:-
M30	33	56	8	50	2115:-	2268:-	2694:-
M33	36	60	8	50	2243:-	3213:-	2970:-
M36	39	68	8	50	2925:-	3294:-	4064:-

BEST.EX: DIN 7989 11 x 21 x 8 FZB

DATA.EX: 7989111

SKÆRMSKIVE

DIN 9021 (~ISO 7093)

UBEHANDLET, FZB

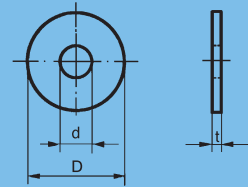

FOR SKRUE	d	D	t	PAKKEP.	PRIS PR. 100 STK.	
					UBEH	FZB
M3	3,2	9	0,8	2000	17:-	20:-
M3,5	3,7	11	0,8	2000		20:-
M4	4,3	12	1,0	2000	24:-	22:-
M5	5,3	15	1,2	2000	44:-	29:-
M6	6,4	18	1,6	1000	68:-	38:-
M7	7,4	22	2	100	102:-	224:-
M8	8,4	24	2	500	122:-	69:-
M10	10,5	30	2,5	200	198:-	136:-
M12	13	37	3	200	405:-	630:-
M14	15	44	3	100	549:-	822:-
M16	17	50	3	100	597:-	935:-
M18	20	56	4	100	1215:-	1755:-
M20	22	60	4	100	1238:-	1868:-

BEST.EX: DIN 9021 3,2 x 9 x 0,8 FZB

DATA.EX: 90210321

A-LOCK LÅSESKIVE

UDEN KAPSEL, MED KAPSEL
FJEDERSTÅL, UBEHANDLET, FNB

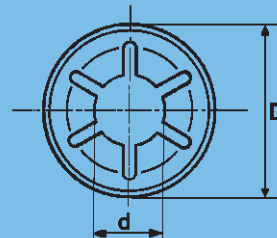

UDEN KAPSEL		PRIS PR. 100 STK.		MED KAPSEL		PRIS PR. 100 STK.	PAKKEP.
d	D	UBEH	FNB	d	D	FNB	
FOR AKSEL				FOR AKSEL			
2	9,5	30:-		2	10	89:-	5000
2	11,3	36:-		2	12	101:-	5000
2,5	6,5	30:-		2,5	7,5	107:-	5000
3	9,5	30:-		3	10	89:-	5000
3	11,3	36:-		3	12	101:-	5000
4	11,3	36:-		4	12	101:-	5000
4	15	44:-		4	16	128:-	5000
5	11,3	36:-	74:-	5	12	101:-	5000
5	15	44:-		5	16	128:-	5000
6	15	44:-	60:-	6	16	128:-	2000
7	15	44:-	69:-	7	16	128:-	2000
8	15	44:-	83:-	8	16	128:-	2000
8	18	62:-		8	19	168:-	2000
8	21	81:-		8	22	204:-	2000
9	18	62:-		9	19	168:-	2000
9	21	81:-		9	22	204:-	2000
9,5	18	62:-	135:-	9,5	19	168:-	2000
10	18	62:-		10	19	168:-	2000
10	21	81:-		10	22	204:-	2000
11	21	81:-		11	22	204:-	1000
12	21	81:-		12	22	204:-	1000
14	21	81:-		14	22	204:-	500
18	36,5	395:-					

BEST.EX: A-LOCK 2 x 9,5 UBEHANDLET
DATA.EX: ARAN02009

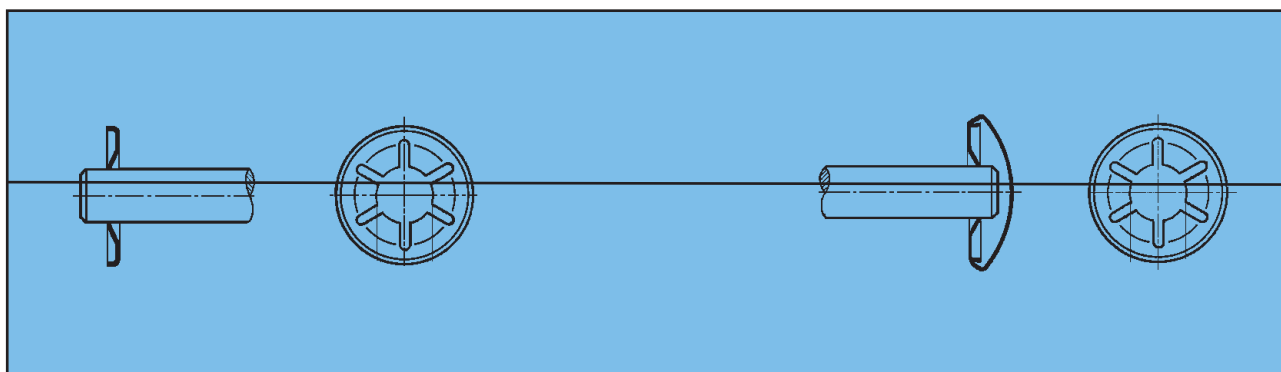

STARLOCK LÅSESKIVE

UDEN KAPSEL
STÅL BRUNLAK, FZB

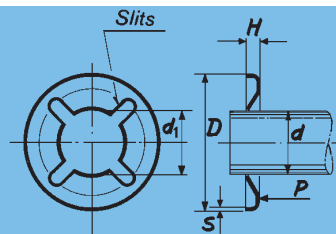

TYPE	d h11 FOR AKSEL	D MAX	H MAX	S	d1	PAKKEP.	P kP	PRIS PR. 100 STK.	
								BRUNLAK PBL	FZB CFZ
P 6489	2	9,7	1,3	0,2	1,75-1,85	10000	35	72:-	86:-
P 6490	3	9,7	1,3	0,2	2,70-2,80	10000	70	72:-	86:-
P 6492	4	11,5	1,3	0,2	3,65-3,75	10000	90	72:-	86:-
P 6491	5	11,5	1,3	0,2	4,65-4,75	10000	90	72:-	86:-
P 6493	6	15,3	1,3	0,25	5,55-5,70	5000	110	81:-	99:-
P 6703	7	15,3	1,3	0,25	6,55-6,70	5000	60	81:-	99:-
P 6704	8	15,3	1,3	0,25	7,50-7,65	5000	165	81:-	99:-
P 6708	9	18,5	2,0	0,30	8,60-8,75	2000	200	101:-	156:-
P 6496	10	18,5	2,0	0,3	9,60-9,75	2000	155	101:-	156:-
P 6706	11	18,5	2,0	0,3	10,60-10,75	2000	215	101:-	156:-
P 6713	12	25	2,4	0,4	11,45-11,60	1000	270	167:-	248:-
P 6829	13	25	2,4	0,4	12,45-12,60	1000	245	167:-	
P 6826	16	28,2	2,4	0,4	15,55-15,70	1000	210	224:-	
P 6716	20	36,5	3,3	0,4	19,40-19,55	500	400	327:-	495:-

BEST.EX: STARLOCK LÅSESKIVE P 6489 BRUNLAK UDEN KAPSEL
DATA.EX: PBL6489

STARLOCK LÅSESKIVE

MED KAPSEL
STÅL BRUNLAK, FZB

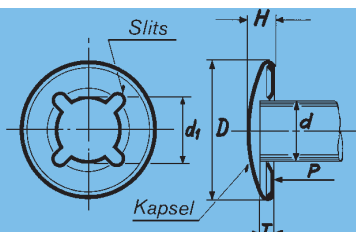

TYPE	d h11 FOR AKSEL	D MAX	H MAX	T	d1	PAKKEP.	P kP	PRIS PR. 100 STK.	
								BRUNLAK CBL	FZB CFZ
C 6662	2	10,7	3,1	2,2-2,4	1,75-1,85	1000	35	182:-	
C 6663	3	10,7	3,1	2,2-2,4	2,70-2,80	1000	70	182:-	189:-
C 6665	4	12,3	3,8	2,4-2,5	3,65-3,75	1000	90	192:-	206:-
C 6664	5	12,3	3,8	2,4-2,5	4,65-4,75	1000	90	192:-	206:-
C 6666	6	16,3	5,1	3,0-3,3	5,55-5,70	1000	110	222:-	242:-
C 6670	7	16,3	5,1	3,0-3,3	6,55-6,70	1000	60	222:-	
C 6671	8	16,3	5,1	3,0-3,3	7,50-7,65	1000	165	222:-	242:-
C 6674	9	19,8	5,8	3,5-3,8	8,60-8,75	1000	200	293:-	
C 6668	10	19,8	5,8	3,5-3,8	9,60-9,75	1000	155	293:-	324:-
C 6673	11	19,8	5,8	3,5-3,8	10,60-10,75	1000	215	293:-	324:-
C 6675	12	26,0	7,5	4,3-4,7	11,45-11,60	500	270	714:-	813:-
C 6882	16	29,4	9,0	6,1-7,1	15,55-15,70	200	210	984:-	
C 6678	20	38,2	11,7	6,1-7,1	19,40-19,55	100	400	1452:-	

BEST.EX: STARLOCK LÅSESKIVE C 6662 2 BRUNLAK MED KAPSEL
DATA.EX: CBL6662

MONTERINGSVÆRKTØJ FOR STARLOCK



HÅNDTAG FOR MAGNETINSATS	PRIS PR. 100 STK.
BEST. NR. PV 6110	88200:-
BEST.EX: HÅNDTAG PV 6110 DATA.EX: PV6110	

MAGNETINSATS FOR HÅNDTAG PV 6110				
FOR AKSELDIAMETER Ø	FOR STARLOCK UDEN KAPSEL BEST. NR.	PRIS PR. 100 STK.	FOR STARLOCK MED KAPSEL BEST. NR.	PRIS PR. 100 STK.
2-3	PV 6111	116550:-	CV 6381	175350:-
4-5	PV 6112	116550:-	CV 6382	175350:-
6-8	PV 6113	116550:-	CV 6383	199500:-
9-11	PV 6114	116550:-	CV 6384	239400:-
12-13	PV 6115	173350:-	CV 6385	432600:-
14-17	PV 6400	327600:-	CV 6893	511350:-
18-22	PV 6118	432600:-	CV 6389	585900:-
BEST.EX: "MAGNETINSATS PV 6111" (FOR HÅNDTAG PV6110) DATA.EX: MAGNETP6111				



se vores hjemmeside
www.bufab.dk

FJEDERSKIVE

DIN 6796

FJEDERSTÅL FOSFATERET/MEKANISK FZB

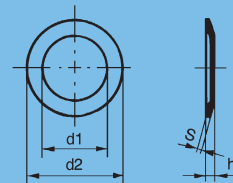

FOR SKRUE	d1	d2	h	h	S	PAKKEP.	PRIS PR. 100 STK.	
							FOS	MEKANISK FZB
M2	2,2	5	0,6	0,5	0,4	100	14:-	15:-
M2,5	2,7	6	0,72	0,61	0,5	100	17:-	20:-
M3	3,2	7	0,85	0,72	0,6	100	18:-	21:-
M3,5	3,7	8	1,06	0,92	0,8	100	29:-	
M4	4,3	9	1,3	1,12	1,0	100	38:-	42:-
M5	5,3	11	1,55	1,35	1,2	100	53:-	62:-
M6	6,4	14	2	1,7	1,5	100	102:-	120:-
M7	7,4	17	2,3	2	1,75	100	179:-	
M8	8,4	18	2,6	2,24	2,0	100	225:-	284:-
M10	10,5	23	3,2	2,8	2,5	100	477:-	585:-
M12	13	29	3,95	3,43	3,0	100	936:-	1152:-
M14	15	35	4,65	4,04	3,5	100	1602:-	1998:-
M16	17	39	5,25	4,58	4,0	100	2466:-	3006:-
M18	19	42	5,8	5,08	4,5	100	3618:-	4230:-
M20	21	45	6,4	5,6	5,0	100	6750:-	7920:-
M22	23	49	7,05	6,15	5,5	100	12600:-	14040:-
M24	25	56	7,75	6,77	6,0	100	13860:-	15840:-
M27	28	60	8,35	7,3	6,5	100	18900:-	21600:-
M30	31	70	9,2	8	7,0	100	22500:-	25920:-

BEST.EX: DIN 6796 2,2 FOSFATERET

DATA.EX: 67960220

SIKRINGSSKIVE

DIN 93

UBEHANDLET, FZB

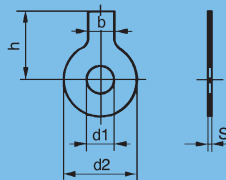

FOR SKRUE	d1	d2	b	s	h	PAKKEP.	PRIS PR 100 STK.	
							UBEH	FZB
M3	3,2	12	4	0,38	13	100	221:-	176:-
M3,5	3,7	12	4	0,38	13	100	221:-	177:-
M4	4,3	14	5	0,38	14	100	156:-	180:-
M5	5,3	17	6	0,5	16	100	156:-	203:-
M6	6,4	19	7	0,5	18	100	179:-	225:-
M8	8,4	22	8	0,75	20	100	221:-	285:-
M10	10,5	26	10	0,75	22	100	257:-	323:-
M12	13,0	30	12	1,0	28	100	347:-	473:-
M14	15,0	33	12	1,0	28	100	522:-	525:-
M16	17,0	36	15	1,0	32	100	486:-	630:-
M18	19,0	40	18	1,0	36	100	675:-	713:-
M20	21,0	42	18	1,0	36	100	567:-	743:-
M22	23,0	50	20	1,0	42	100	891:-	990:-
M24	25,0	50	20	1,0	42	100	936:-	1026:-

BEST.EX: DIN 93 3,2 FZB

DATA.EX: 9330321

SIKRINGSSKIVE

DIN 463
FZB

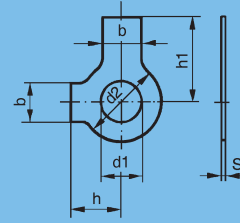

FOR SKRUE	d1	d2	b	s	h	h1	PAKKEP.	PRIS PR. 100 STK. FZB
M4	4,3	9	5	0,38	6,5	14	100	177:--
M5	5,3	10	6	0,5	8	16	100	195:--
M6	6,4	12,5	7	0,5	9	18	100	219:--
M8	8,4	17	8	0,75	11	20	100	288:--
M10	10,5	21	10	0,75	13	22	100	324:--
M12	13	24	12	1,0	15	28	100	410:--
M14	15	28	12	1,0	16	28	100	464:--
M16	17	30	15	1,0	18	32	100	585:--
M18	19	34	18	1,0	20	36	100	657:--
M20	21	37	18	1,0	21	36	100	723:--
M22	23	39	20	1,0	23	42	100	1020:--
M24	25	44	20	1,0	25	42	100	1074:--
M27	28	50	23	1,6	29	48	100	2060:--
M30	31	56	26	1,6	32	52	100	2289:--
M33	34	60	28	1,6	34	56	100	2552:--
M36	37	66	30	1,6	38	60	100	2930:--
M39	40	72	32	1,6	41	64	100	3321:--

BEST.EX: DIN 463 4,3 FZB
DATA.EX: 4630431